



## Article

# The Mediating Effect of the Internal Control System on the Relationship between the Accounting Information System and Employee Performance in Jordan Islamic Banks

Baker Akram Falah Jarah <sup>1,\*</sup> , Nidal Zaqeeba <sup>2</sup>, Mefleh Faisal Mefleh Al-Jarrah <sup>3</sup> ,  
Abdalla Mohammad Al Badarin <sup>3</sup> and Zeyad Almatarneh <sup>1,\*</sup>

<sup>1</sup> Department of Accounting, Faculty of Business, Amman Arab University, Amman 11953, Jordan

<sup>2</sup> Department of Finance & Banking Science, Faculty of Administrative & Financial Sciences, Irbid National University, Irbid 21110, Jordan

<sup>3</sup> Islamic Economics and Banking Department, Faculty of Shari and Islamic Studies, Yarmouk University, Irbid 21163, Jordan

\* Correspondence: dr.baker@aau.edu.jo (B.A.F.J.); zmatarneh@aau.edu.jo (Z.A.)

**Abstract:** The goal of the current study is to determine how the internal control system (ICS) in Jordanian Islamic banks affects the link between the accounting information system (AIS) and employee performance (EP). The study's target audience is actual Jordanian Islamic Bank workers, and a sample of 92 respondents, representing a response rate of about 70.22%, was selected from a total of 131 participants, themselves divided among 105 branches of Islamic Banks in Jordan. According to the data, there is a clear correlation between the AIS, which comprises information quality (IQ), system quality (SQ1), and service quality (SQ2), and the EP in Jordanian Islamic Banks, at a significance level of 0.00. Furthermore, it was demonstrated that the impact of the ICS on the relationship between AIS and EP in Jordanian Islamic banks was statistically significant.

**Keywords:** accounting information system; information quality; system quality; service quality; internal control system; employee performance; Jordan Islamic Banks

**JEL Classification:** M00; M41; M49



**Citation:** Jarah, Baker Akram Falah, Nidal Zaqeeba, Mefleh Faisal Mefleh Al-Jarrah, Abdalla Mohammad Al Badarin, and Zeyad Almatarneh. 2023. The Mediating Effect of the Internal Control System on the Relationship between the Accounting Information System and Employee Performance in Jordan Islamic Banks. *Economies* 11: 77. <https://doi.org/10.3390/economies11030077>

Academic Editor: Ștefan Cristian Gherghina

Received: 17 January 2023

Revised: 20 February 2023

Accepted: 21 February 2023

Published: 27 February 2023



**Copyright:** © 2023 by the authors. Licensee MDPI, Basel, Switzerland. This article is an open access article distributed under the terms and conditions of the Creative Commons Attribution (CC BY) license (<https://creativecommons.org/licenses/by/4.0/>).

## 1. Introduction

To keep track of incoming and outgoing funds, every bank requires an accounting information system (AIS), which has been carefully established and maintained, wherein the AIS enables the bank to achieve its objectives (Jarah and Iskandar 2019a). Therefore, the AIS is an IT-based solution that aids in the control of an organization's economic and financial operations. However, significant technological improvements have made it possible for businesses to use this choice strategically (Alnajjar 2017). Additionally, decision makers can obtain pertinent information from the AIS and use it in decision-making and strategy formulation to assist the bank in meeting its goals and objectives, thereby improving the bank's performance. Furthermore, AIS are utilized in banks to assist with data processing to optimize staff performance based on each employee's duties and responsibilities (Nugroho 2019).

Because many banks' primary motivations for implementing this system are increasing their bank's efficiency and competitiveness, any AIS's qualitative characteristics can be preserved if a practical ICS is in place to ensure that operational goals and performance are met (Hla and Teru 2015). The AIS is also intended to help with the administration and control of economic and financial subjects within a bank. Accounting data, on the other hand, can now be created and strategically employed thanks to technological advancements. Previously, the AIS was primarily concerned with recording, summarizing, and validating commercial financial transaction data (Soudani 2012).

However, the AIS provides several methods and processes that make internal control system operations easier (Susanto 2016). Additionally, the bank's AIS is regarded as a primary source of information for making decisions, as these systems provide various beneficiaries with the information and financial statements required for planning, regulating, and making decisions (Almatarneh et al. 2022). Furthermore, the AIS simplifies the bank's operations, allowing it to gain a competitive edge by executing procedures with fewer mistakes (Al Hanini 2015).

Similarly, the output qualities provided by the AIS, the system characteristics, are the focus of service and information quality. As a result, the right quality of provider's system is required for organizational benefit and success, since it is favorably associated with increased profitability, customer loyalty, and competitive advantage (Ranganath and Rajeshwaran 2022). As a measure of information quality efficacy, service quality is defined as the quality of help that system users receive from the information systems organization and IT support personnel (Gorla et al. 2010).

Therefore, the objective of ICS is to safeguard owned assets, evaluate the accuracy of the AIS, and examine operational data in the bank (Fakhimuddin 2018). The role of the AIS in managing a bank and implementing an ICS is critical, and the ultimate goal of the AIS is to collect and record information and data relevant to matters that can have a financial impact on the bank, as well as to ensure operational efficiency and effectiveness, financial data reliability, and legal compliance (Teru et al. 2017). The AIS, as one of the most critical systems in the organization, has altered the way that data are captured, processed, stored, and distributed. In today's AIS, digital and online data are increasingly being utilized (Saeidi and Prasad 2014).

Furthermore, the AIS has a substantial impact on the efficacy of the ICS, where the AIS refers to instruments and methods for acquiring and interpreting financial data so that accountants and executives may make informed decisions (Alawaqleh 2021). The AIS requires several processes and procedures to facilitate internal control operations. This involves encouraging teamwork, exchanging information with the chain of command, and holding the bank's management accountable for increasing EP (Jarrah and Almatarneh 2021). Internal control of a bank is a difficult procedure to master. To maintain control, a manager requires a large amount of information from the bank (Jarrah and Iskandar 2019b). The AIS is one method of obtaining the information required in the control process; additionally, internal control is a component of the evaluation process for monitoring the execution of bank activities (Ali et al. 2016).

However, the AIS and its performance are affected by the complexity of the issues influencing the Islamic Bank's performance. AIS are a source of financial data that impact performance; nevertheless, other elements such as the decision-making process, decision quality, dynamic employees in the bank, and efficiency and effectiveness also have an impact. Moreover, the quality of the AIS owned by Islamic banks has an impact on the nature of reporting, which in turn has an impact on the bank's success. Therefore, concerns raised in this study stem from a drop in EP in Jordanian Islamic Banks; this is caused by weaknesses in the ICS, a lack of appropriate information, and top-level Islamic Banks managers' unwillingness to provide computerized AIS to their banks, all of which have an impact on EP. According to (Jarrah and Iskandar 2019a; Jarrah and AL Jarrah 2022; Al-Zoubi 2017; Wongsim and Hongsakon 2015; Alawaqleh 2021; Khan 2016; Ladan Shagari et al. 2017), Jordanian banks do not use AIS efficiently or successfully. Therefore, this study aims to look into the relationship between the AIS and EP in Jordanian Islamic banks, including IQ, SQ1, and SQ2. In addition, the ICS's mediating influence on the relationship between the AIS and EP will be investigated. In the literature review, however, no studies addressing ICS as a mediating variable to the impact of AIS on EP were found. Additionally, this conceptual framework focuses on this knowledge gap and asks, "What effect does AIS have on EP in Jordanian Islamic banks when it is mediated by ICS?"

## 2. Literature Review

The AIS is a network that connects physical and non-physical subsystems to turn financial transaction data into information. AIS produces information by processing data resources which include people, data, hardware, software, and network resources (Binh et al. 2022). The creation of successful AIS has a significant impact on the performance and operational effectiveness of businesses, because management needs consistent and correct information to make decisions (Sabri et al. 2022). The AIS utilized by the Jordanian banks offers access to important information and aids in the confirmation of the outcome of planned actions (Burgos et al. 2022). The AIS used by Jordanian banks provides access to critical information and aids in the verification of the outcome of planned actions, because the system handles requests for changes to existing systems and generates annual reports that include forward-looking information that aids in the development of expectations and projections for the bank's future. In addition, the system assists senior management in developing and implementing bank policies (Bukenya 2014; Matovu 2011; Al-Dmour et al. 2017).

Furthermore, AIS are very important to many internal and external parties because they provide a variety of benefits that meet their needs, such as daily information on bank activities. The AIS assists decision-making by providing all of the data and accounting information needed to support bank decisions (Zuo and Lin 2022). However, the AIS also improves employee efficiency and makes better use of the Islamic Bank's human resources, helping to organize work within the bank by clarifying duties and reducing errors (Jarrah et al. 2022a). Also, the AIS is the existence of an information system that can aid banks in making information available to consumers or users (Gunawan and Nengzih 2023).

### 2.1. Accounting Information System (AIS)

The AIS is a system that collects and saves data about the bank's activities, translates the data into information helpful to management, generates plans, and provides necessary controls to protect organizational assets. As a result, effective AIS are crucial to the long-term functioning of any bank (Onalapo and Odetayo 2012). The AIS is a data collection, recording, storage, and management system used to generate information for decision-makers (Romney and Steinbart 2006) in which the data processing cycle is divided into four stages: data input, data storage, data management, and information outcomes (Fakhimuddin 2018).

Among other things, the bank's management must go to great lengths to maintain the security of ICS entry, registration, and processing (Al Hanini 2015). Because the major goal of AIS is to govern every organization's operations, management or accountants can achieve this goal by developing an effective ICS. Without adequate internal controls on AIS, banks will be susceptible to fraud (Teru et al. 2017). As a result, the AIS must provide precise data on all bank data, including financial reports and staff absences (Fakhimuddin 2018). The basic goal of AIS is to provide a numerical value to past, present, and future economic events. The information generated by the bank's AIS is only financial because the AIS is only used to handle financial data (Nugroho 2019). The AIS is a tool that bank executives use to add value and gain a competitive advantage. The AIS' roles also include providing critical information to reduce uncertainty, assisting with decision-making, and supporting improved work activity planning, scheduling, and management (Fitriati and Mulyani 2015).

Furthermore, the AIS must be reliable in its operation and provide accurate, trustworthy information to its users in a timely and relevant manner. To protect the integrity of the information and the bank's resources, acceptable internal control must be implemented, and to do so, the bank must prioritize such systems and consider both system- and employee-related issues while managing their AIS (Jarrah and Iskandar 2019b). Additionally, when it comes to running a bank and putting in place an ICS, the importance of the AIS cannot be overstated (Saeidi and Prasad 2014). This is because the AIS is a computer-based system that maintains the quality of accounting data, boosts control, and

improves collaboration in an organization by making data visible and accessible to end users with similar needs, and the AIS also encompasses a collection of records, procedures, and equipment that customarily handles events impacting the bank's EP and position (Jarrah and Almatarneh 2021).

### 2.2. Information Quality (IQ)

The IQ refers to the quality of outputs produced by AIS, and it has become extremely important for banks that want to project superior performance, gain competitive advantages, or survive in today's business environment (Ali et al. 2016). The IQ refers to a system's ability to provide a user with timely, accurate, appropriate, and complete data for successful decision making (Ladan Shagari et al. 2017).

### 2.3. System Quality (SQ1)

The SQ is a measure of how technically sound the system is, and it refers to the processing quality of the AIS as a whole, including software and data components. Furthermore, SQ is concerned with whether the system is free of flaws, the consistency of the user interface, and the ease of usage (Gorla et al. 2010). The SQ has the potential to influence use, user satisfaction, individual performance, and bank performance (Ali et al. 2016). The SQ is concerned with the system's technical efficiency, including user interface consistency, ease of use, and programming errors, as well as the system's maintainability, assurance, and the empathy of the bank's information technology departments, all of which contribute to the system's efficient operation and greater AIS effectiveness (Ladan Shagari et al. 2017).

### 2.4. Service Quality (SQ2)

The SQ metric assesses a bank's ability to meet and exceed customer expectations by calculating the difference between the client's expectations for a service offering and the customer's perceptions of the service obtained (Akdere et al. 2020). SQ can also be defined as the level of service provided by information technology service providers to business users in terms of dependability, responsiveness, assurance, and empathy. These SQ ideas may be implemented into information systems that meet user expectations by delivering services on time, increasing user confidence, and being pleasant to users while meeting service demands (Gorla et al. 2010).

### 2.5. Internal Control Systems (ICS)

Internal control is a process influenced by a company's board of directors, management, and other employees (Jarrah et al. 2022b). Additionally, the ICS must ensure that all essential economic events are collected by the AIS and that the process of altering and summarizing financial data is error-free (Napitupulu 2020). Furthermore, according to Sagala (2020), internal control is a policy to protect assets from misuse, verify the correctness of corporate information, and ensure that applicable laws and regulations are obeyed. Additionally, internal control seeks to keep things in the bank from happening by accident or on purpose; instead, decisions should be made via the internal control process, and "top management" refers to the information examined during the control process when adopting policies or making judgments (Fakhimuddin 2018).

Control activities are one of the components of internal control, and while carrying out management, control activities, rules, procedures, and sanctions for potential risks will be developed (Maharani and Damayanthi 2020). Therefore, the ICS must ensure that all essential economic events are collected by the AIS and that the process of altering and summarizing financial data is error-free (Napitupulu 2020). According to Sagala (2020), internal control is a policy to protect assets from misuse, verify the correctness of corporate information, and ensure that applicable laws and regulations are obeyed. A good ICS ensures that financial and managerial reporting is accurate, and that a bank's long-term profitability goals and objectives are reached.

According to [Salehi et al. \(2013\)](#), the ICS is a process influenced by a bank's board of directors and other people to whom the bank intends to provide reasonable confidence about the achievement of its objectives. This process is neither a procedure nor a policy that can be accomplished at any special level, but it is a matter that is in continuous circulation at all levels of a bank. Furthermore, [Abd Aziz et al. \(2015\)](#) note that ICS is a multidimensional notion that has been studied in the management control literature in a variety of ways; a good ICS will assist a bank in preventing bad financing, and will also assist it in working properly and in harmony while discovering faults and inconsistencies in its operations ([Jarrah et al. 2022b](#)). As a result, banks acknowledge the importance of their ICS and risk management, both of which are considered essential tools in ensuring the overall success of the bank's objectives and the enhancement of shareholder value. This makes it easier for the administration to fulfill its main obligations, including performance assessment, coordination, planning, and control ([Al-Zaqeba et al. 2022](#)).

### 2.6. Employee Performance (EP)

The employee is an important part of the bank; banks are now making significant investments in staff development, one of the most crucial aspects of human resource management. Therefore, employee productivity and output, or EP, will eventually have an impact on the bank's organizational performance, according to [Hameed and Waheed \(2011\)](#). EP is essentially work outcomes and accomplishments; thus, EP is dictated by talent, desire, and environment, and EP is influenced by the many different qualities of each individual. As a result of the emergence of a competitive and globalized era, banks unquestionably require high achievers ([Diamantidis and Chatzoglou 2019](#)).

Therefore, the tasks that are given to a person depending on his talent, experience, ability, and time determine how well they are performed ([Sagala 2020](#)). [Diamantidis and Chatzoglou \(2019\)](#) define "performance" as the total result or success of an individual throughout particular periods of duty regarding their job, their objectives, or standards that have been specified in advance and agreed upon. EP may also refer to the employee's financial or non-financial repercussions, which are connected to the success and performance of the bank ([Anitha 2014](#)). As a result, EP includes output quantity and quality, presence at work, a helpful and accommodating attitude, and timely output. EP is impacted by motivation, since inspired individuals will work more and produce better work as a consequence ([Shahzadi et al. 2014](#)).

The AIS components, including IQ, SQ, and SQ, have an impact on EP in Jordanian Islamic Banks alongside the mediating role of the ICS in the relationship between AIS and EP. Both of these elements were thus studied by the researchers. Therefore, the internal control system has arisen in the modern period as the essential means of continuously monitoring, managing, checking, and reviewing processes. The AIS also allows the ICS to create accounting and financial reports on time, improving the efficacy and efficiency of the internal control process. Furthermore, AIS are the most crucial and effective tools for the bank's ICS to carry out its tasks efficiently. Similarly, the AIS provides accounting information to internal control aids for the detection of errors and manipulations.

Taking into account the above contributions, outcomes, and gaps, the following hypotheses have been developed:

**H0.1.** *AIS does not affect EP.*

The authors stated the H0.1 in three sub-hypotheses as follows:

**H0.1.1.** *IQ does not affect EP.*

**H0.1.2.** *SQ1 does not affect EP.*

**H0.1.3.** *SQ2 does not affect EP.*



**H0.2.** *AIS does not affect ICS.*

The authors stated the H0.2 in three sub-hypotheses as follows:

**H0.2.1.** *IQ does not affect ICS.*

**H0.2.2.** *SQ1 does not affect ICS.*

**H0.3.3.** *SQ2 does not affect ICS.*

**H0.3.** *ICS does not affect EP.*

**H0.4.** *ICS has not mediated the effect of AIS on EP.*

The authors stated the H0.4 in three sub-hypotheses as follows:

**H0.4.1.** *IQ has not mediated the effect of AIS on EP.*

**H0.4.2.** *SQ1 has not mediated the effect of AIS on EP.*

**H0.4.3.** *SQ2 has not mediated the effect of AIS on EP.*

### **3. Methodology**

#### *3.1. Study Population*

The study population consists of Jordan Islamic Banks employees in practice, with a sample of 92 respondents chosen from a population of 131 with around a 70.22% response rate, divided among 105 branches of Islamic Banks in Jordan. Data were collected from respondents using a questionnaire based on a simple random sampling procedure using the quantitative research approach. In addition, two phases of the partial least square version 3 (SEM-PLS) methods were applied.

#### *3.2. Sampling Technique and Data Collection Procedures and Measures*

Our aim was to investigate the impact of the AIS (including IQ, SQ1, and SQ2) on EP in Jordanian banks, as well as the mediating effect of the ICS on the relationship between AIS and EP. A questionnaire was developed based on previous studies related to the subject of the study. The administered questionnaire consists of four parts that were tailored to the topic of the current investigation. The first section includes the employees' demographics (gender, qualification, and experience), the second section contains 16 AIS components as independent variables, each represented by three variables (five items to measure the IQ from a1 to a5, six items to measure the SQ1 from b1 to b6, and five items to measure the SQ2, from c1 to c5). In addition, the third section includes nine items to measure the ICS from d1 to d9, and the fourth section contains eight items to measure the EP from e1 to e8, where the first stage investigates variable reliability and validity and the second assesses hypotheses. This is shown in Table 1.

**Table 1.** Demographic information.

Description	Variable	Result	Percentage
Gender	Male	82	89.1%
	Female	10	10.9%
Qualification	Bachelor's	56	60%
	Master's	30	32.6%
	Doctorate	6	6.5%
Experience	Less than 5 years	10	10.9%
	From 6 years to less than 10 years	27	29.3%
	From 11 years to less than 15 years	37	40.2%
	From 16 years & more	18	19.6%

Based on the above literature review, the researchers developed the research model as shown in Figure 1.

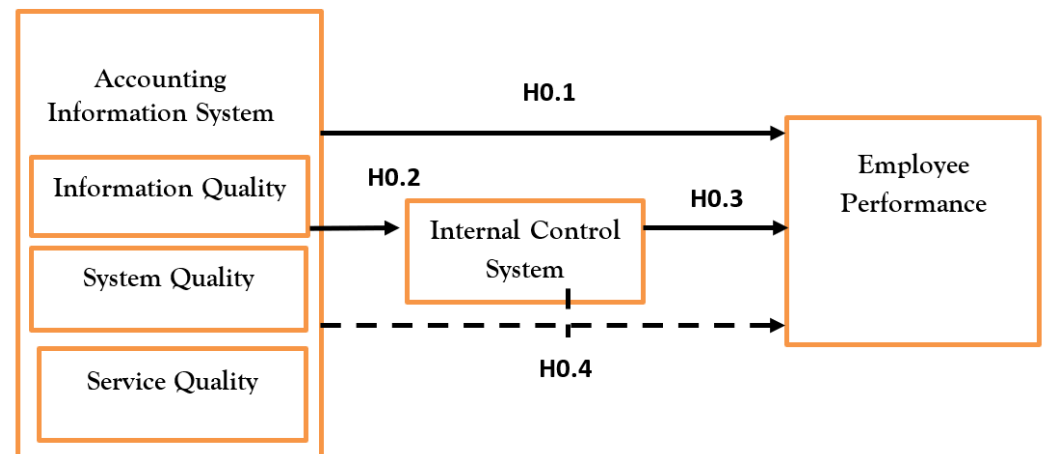
**Figure 1.** Research model.

#### 4. Data Analysis and Result

##### 4.1. Data Analysis

A partial least-squares (SEM-PLS, version 3) technique was applied twice in this investigation (Anderson and Gerbing 1988). The variables' consistency and validity were checked in the first stage, and hypotheses were evaluated in the second.

##### 4.2. The Measurement Criteria

Firstly, Figure 2 shows the path loadings. Furthermore, if each element's factor loading is equal to or greater than 0.70, the factor can be used for analysis (Hair et al. 2017).

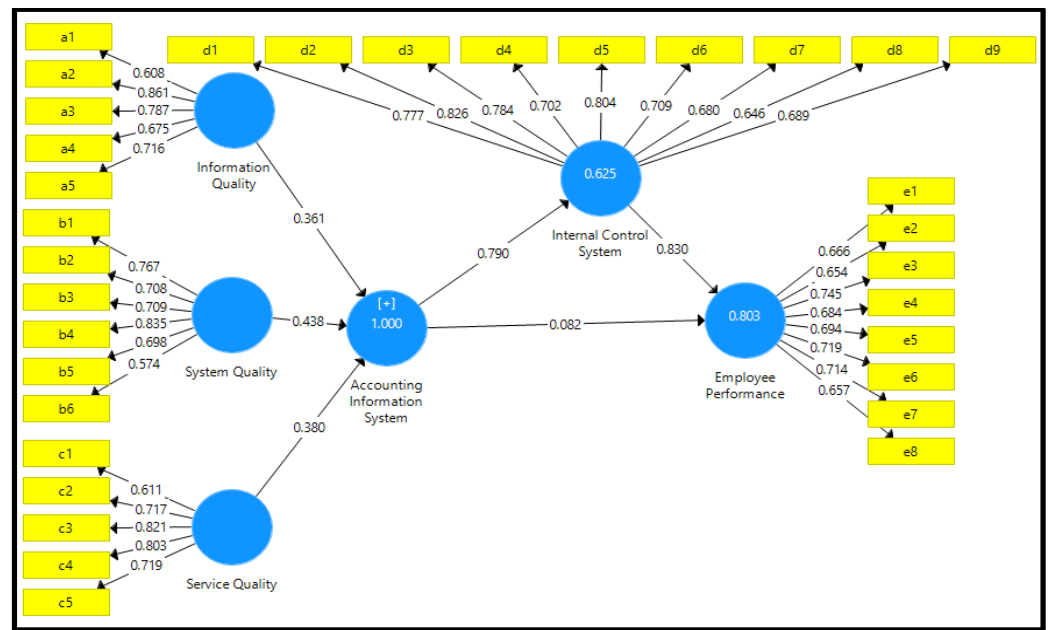

Figure 2. Factor loadings result for the proposed mode.

As indicated in Table 2, the factor loadings for entire items exceeded the prescribed value of 0.70, except for items (a1, b5, b6, c1, d7, d8, d9, e1, e2, e4, e5, and e8), which were excluded from the scale due to inappropriate loadings.

Table 2. Factor loadings for the proposed model.

Construct	Item	Loading (>0.7)	Result
Information quality (IQ)	a1	0.608	Not accept
	a2	0.861	Accept
	a3	0.787	Accept
	a4	0.675	Accept
	a5	0.716	Accept
System quality (SQ1)	b1	0.767	Accept
	b2	0.708	Accept
	b3	0.709	Accept
	b4	0.835	Accept
	b5	0.698	Not accept
	b6	0.575	Not accept
Service quality (SQ2)	c1	0.611	Not accept
	c2	0.711	Accept
	c3	0.821	Accept
	c4	0.803	Accept
	c5	0.719	Accept



Table 2. Cont.

Construct	Item	Loading (>0.7)	Result
Internal control system (ICS)	d1	0.777	Accept
	d2	0.826	Accept
	d3	0.784	Accept
	d4	0.702	Accept
	d5	0.804	Accept
	d6	0.709	Accept
	d7	0.680	Not accept
	d8	0.646	Not accept
	d9	0.686	Not accept
Employee performance (EP)	e1	0.666	Not accept
	e2	0.654	Not accept
	e3	0.745	Accept
	e4	0.684	Not accept
	e5	0.694	Not accept
	e6	0.719	Accept
	e7	0.714	Accept
	e8	0.657	Not accept

Second, in the path loadings for the modified model at the start, the variables (a1, b5, b6, c1, d7, d8, d9, e1, e2, e4, e5, and e8) became less than 0.70, so they were removed. See Figure 3.

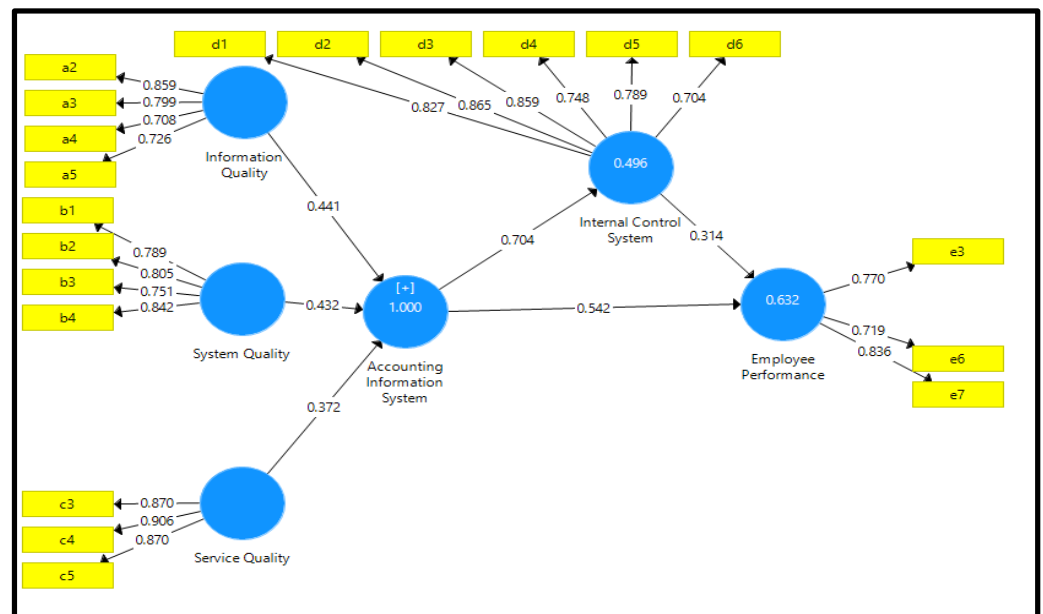

Figure 3. Factor loadings for the modified model.

Based on Figure 3, this study examines the path loadings for the modified model shown in Table 2. All path loadings become above 0.70 and are therefore accepted (Hair et al. 2017).

Third, Cronbach’s alpha is used to measure dependability in this study. Cronbach’s alpha exceeded the required threshold of 0.70 (Sekaran and Bougie 2016). As seen in Table 3,

this indicates that reliability is met, and a Cronbach's alpha greater than 0.65 is considered good (Hair et al. 2017).

**Table 3.** Displays the path loading for the modify model, Cronbach's alpha, CR, and AVE.

Construct	Item	Loading (>0.7)	Result	Cronbach's Alpha (>0.7)	CR (>0.7)	AVE (>0.5)
IQ	a2	0.859	Accept	0.77	0.85	0.60
	a3	0.799	Accept			
	a4	0.708	Accept			
	a5	0.726	Accept			
SQ1	b1	0.789	Accept	0.81	0.87	0.63
	b2	0.805	Accept			
	b3	0.751	Accept			
	b4	0.842	Accept			
SQ2	c3	0.870	Accept	0.85	0.91	0.77
	c4	0.906	Accept			
	c5	0.870	Accept			
ICS	d1	0.827	Accept	0.70	0.91	0.64
	d2	0.865	Accept			
	d3	0.859	Accept			
	d4	0.748	Accept			
	d5	0.789	Accept			
	d6	0.704	Accept			
EP	e3	0.770	Accept	0.67	0.82	0.60
	e6	0.719	Accept			
	e7	0.836	Accept			

Furthermore, every composite reliability (CR) was greater than 0.70 (Hair et al. 2017), indicating that composite reliability is met, as shown in Table 3.

Fourth, as shown in Table 3, this study examined the extracted average variance (AVE) and discovered that all AVE values were higher than the suggested value of 0.50 (Hair et al. 2017); this implies that the convergent validity is met.

Fifthly, Table 4 shows how this study investigated discriminant validity using the Fornell–Larcker criterion.

**Table 4.** Discriminant validity by Fornell–Larcker Criterion.

Factors	IQ	SQ	SQ	ICS	EP
IQ	0.775				
SQ1	0.541	0.798			
SQ2	0.504	0.334	0.882		
ICS	0.548	0.650	0.504	0.801	
EP	0.690	0.533	0.739	0.695	0.777

According to Table 4, the correlation between exogenous constructs is less than 0.85, and is good if it is less than 0.90 (Hair et al. 2017). As a result, the discriminant validity of entire constructs is achieved.

### R-Squared Test

The R-squared value is evaluated with and without the mediating variable (the internal control system), as can be seen in Table 5.

**Table 5.** R-squared value.

Factor	R (Square)
AIS on EP without ICS as a mediating variable	0.490
AIS on EP with ICS as a mediating variable	0.632

Referring to Table 5, the R-squared EP without mediation is 0.490; this is greater than 25%, indicating that the condition is met (Gaur and Gaur 2006). Furthermore, the R-squared EP over mediation is 0.632, which is greater than 25%, indicating that the condition is met (Gaur and Gaur 2006). When the ICS is used as a mediation concept in the relationship between the AIS and EP, the R-squared value increases by 14.2% (from 0.49% to 0.632%).

### 4.3. Hypotheses Test

The proposed model illustrated in Figure 1 has three direct and indirect hypotheses among the constructs for the AIS (Information Quality, System Quality, and Service Quality) as the independent variable; ICS is a mediating variable, and EP is a dependent variable. A graphic diagram of the hypotheses test is shown in Figure 4.

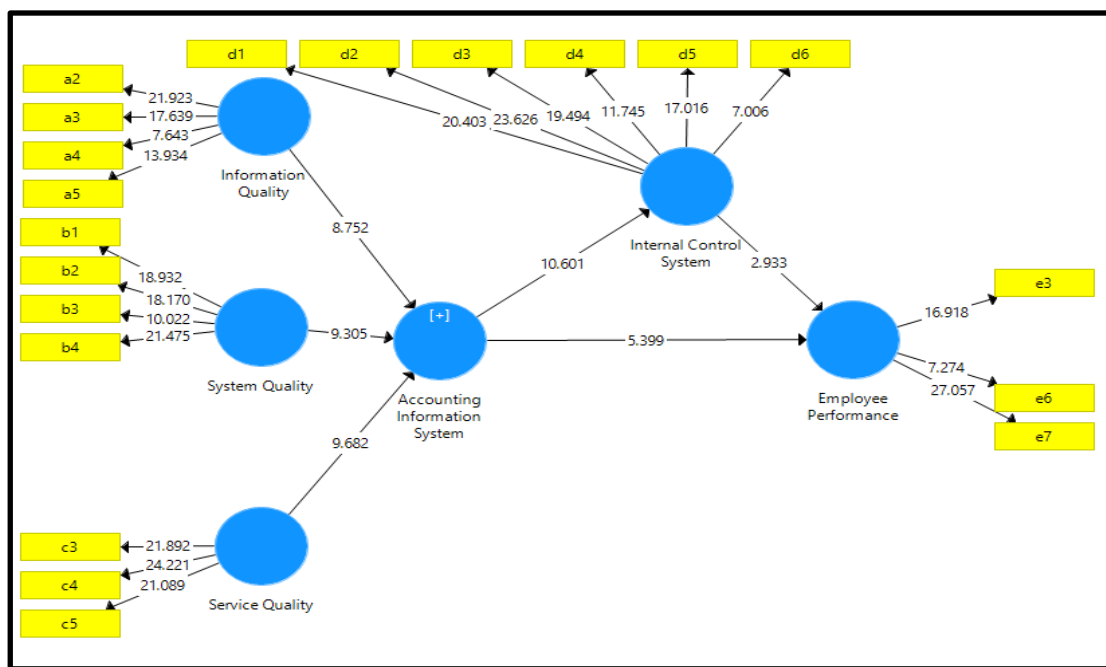

**Figure 4.** The T-value statistics using bootstrapping.

As shown in Figure 4, we used clever PLS.3 to calculate the T-value for each hypothesis (H0.1, H0.1.1, H0.1.2, H0.1.3, and H.3). Table 6 summarizes the results.

**Table 6.** Structural path analysis result.

Relation (Direct Effect) Hypothetical Path	T-Value	p-Value	Beta Path Coefficient	Result
AIS → EP	2.399	0.000	0.542	Supported
IQ → EP	8.051	0.000	0.704	Supported
SQ1 → EP	10.214	0.000	0.337	Supported
SQ2 → EP	8.439	0.000	0.284	Supported
AIS → ICS	10.601	0.000	0.704	Supported
IQ → ICS	10.361	0.000	0.311	Supported
SQ1 → ICS	7.630	0.000	0.304	Supported
SQ2 → ICS	8.018	0.000	0.262	Supported
ICS → EP	2.933	0.000	0.314	Supported

The T-value between AIS and EP is 2.399 in Table 6, which is higher than 1.96 (Hair et al. 2017). As a result, it is significant at 0.01. The hypothesis that H0.1: AIS has no direct impact on EP is rejected, since the value of beta is 0.542, which shows that altering one aspect of the AIS will alter EP by 0.542.

The T-value between IQ and EP is 8.051 in Table 6, which is higher than 1.96 (Hair et al. 2017). It is therefore significant at 0.01; additionally, the beta value of 0.704 indicates that changing one part of IQ causes a change in EP of 0.704, contradicting the hypothesis that IQ has no direct impact on EP.

The T-value between SQ1 and EP is 10.214 in Table 6, which is higher than 1.96 (Hair et al. 2017). As a result, it is significant at 0.01. The hypothesis of H0.1.2: SQ1 having no direct influence on EP is rejected, since the beta value of 0.337 shows that altering one component of SQ1 would alter EP by 0.377.

The T-value between SQ2 and EP is 8.439 in Table 6, which is higher than 1.96 (Hair et al. 2017). As a result, it is significant at 0.01. The hypothesis that H0.1.3: SQ2 has no direct influence on SQ2 is rejected, since the value of beta is 0.284, which means that changing one aspect of SQ2 would change EP by 0.284.

The T-value between AIS and ICS is 10.601, which is higher than 1.96, as shown in Table 6 (Hair et al. 2017). As a result, it is significant at 0.01. Additionally, the value of beta is 0.704, which disproves the hypothesis that the AIS has no direct effect on the ICS by showing that changing one component of the AIS will change the ICS by 0.704.

The T-value between IQ and ICS is 10.361, which is higher than 1.96, as shown in Table 6 (Hair et al. 2017). As a result, it is significant at 0.01. The hypothesis that H0.2.1: IQ has no direct effect on the ICS is rejected, since the beta value is 0.311, which shows that altering one aspect of IQ would alter the ICS by 0.311.

The T-value between SQ1 and ICS is 7.630 in Table 6, which is higher than 1.96 (Hair et al. 2017). As a result, it is significant at 0.01. The hypothesis of H0.2.2: SQ1 having no direct influence on ICS is rejected, since the beta value is 0.304, which shows that changing one element in the SQ1 will change the ICS by 0.304.

The T-value between SQ2 and ICS is 8.018 in Table 6, which is higher than 1.96 (Hair et al. 2017). As a result, it is significant at 0.01. The hypothesis that H0.2.3: SQ2 has no direct influence on the ICS is rejected, since the beta value, which is 0.262, shows that altering one element of the SQ2 will modify the ICS by 0.262.

The T-value between ICS and EP is 2.933 in Table 6, which is higher than 1.96 (Hair et al. 2017). It is therefore significant at 0.01; additionally, the beta value of 0.314 indicates that changing one section of the ICS will change EP by 0.314, contradicting the hypothesis that the ICS has no direct impact on EP.

The outcomes of the hypotheses tests are shown in Table 7 for H0.4, H0.4.1, H0.4.2, and H0.4.3.

**Table 7.** The test results for the fourth hypothesis.

Hypotheses	Hypothetical Path	Direct Effect T Value	Direct Effect Beta	Indirect Effect Beta	Total Effect T Value	Total Effect Beta	Result
H0.4	AIS → ICS	10.601	0.704		10.601	0.704	Supported
	ICS → EP	2.933	0.314		2.933	0.314	Supported
	AIS → EP by ICS			0.221			Supported Partially mediate
	AIS → EP	2.399	0.542		18.075	0.763	Supported
H0.4.1	IQ → ICS	10.631	0.311		10.631	0.311	Supported
	ICS → EP	2.933	0.314		2.933	0.314	Supported
	IQ → EP by ICS			0.097			Supported Partially mediated
	IQ → EP	8.051	0.704		8.051	0.801	Supported
H0.4.2	SQ1 → ICS	7.630	0.304		7.630	0.304	Supported
	ICS → EP	2.933	0.314		2.933	0.314	Supported
	SQ1 → EP by ICS			0.095			Supported Partially mediated
	SQ1 → EP	10.214	0.377		10.214	0.472	Supported
H0.4.3	SQ2 → ICS	8.018	0.262		8.018	0.262	Supported
	ICS → EP	2.933	0.314		2.933	0.314	Supported
	SQ2 → EP by ICS			0.082			Supported Partially mediated
	SQ2 → EP	8.439	0.284		8.439	0.633	Supported

The T-value between AIS, IQ, SQ1, SQ2, and ICS is larger than 1.96 (Hair et al. 2017). As a result, it is statistically significant at 0.01, as shown in Table 7.

Furthermore, the T-value between ICS and EP is larger than 1.96 (Hair et al. 2017). As a result, it is statistically significant at 0.01.

Furthermore, the indirect effect beta result is 0.221, meaning that a single change in the AIS and ICS results in a 0.221 change in EP.

Furthermore, the indirect influence beta is 0.097, meaning that a single change in the IQ and ICS results in a 0.097 change in EP.

Furthermore, the indirect impact has a beta value of 0.095, meaning that altering a single piece in SQ1 and ICS results in a 0.095 change in EP.

Furthermore, the beta value for the indirect impact is 0.082, showing that a single change in the SQ2 and ICS results in an EP change of 0.082.

Finally, the T-values of AIS, IQ, SQ1, SQ2, and EP all exceed 1.96 (Hair et al. 2017). The hypotheses are endorsed and partially mediated as a result of H0.4, H0.4.1, H0.4.2, and H0.4.3.

## 5. Discussion

The use of AIS for information required by various bank users is common; it has an impact on decision making and supports organizational and administrative coordination in banks. The study by Bani Ahmad (2022) discovered that the biggest positive impact comes from the quality of information and data, indicating an essential factor that influ-

ences the use of AIS in the banking industry. In the same context, any AIS's qualitative characteristics can be preserved if an effective ICS is in place (Albashesheh et al. 2018). The AIS, on the other hand, is focused on data and information that are both financial and non-financial (Dandago and Rufai 2014). Furthermore, any bank's AIS must have a way to keep track of and manage data until system users submit reports with accurate information, wherein accountants play a critical role in developing and evaluating AIS control and safety standards (Jarrah and AL Jarrah 2022). Therefore, if a bank has effective internal control, management may rely on information to correctly maintain its commercial processes. However, if internal controls are weak, the bank's management will fail to meet its objectives (Neogy 2014). In addition, a bank's ICS must be appropriate in order to support flawless AIS (Nugroho 2019).

According to Napitupulu (2020), managers' competencies influence the quality of AIS and internal control in banks. According to the findings of the Susanto (2016) study, internal control affects the AIS. In the study by Maharani and Damayanthi (2020), results showed that internal controls and business culture influence AIS and EP. Organizational culture influences EP and organizational culture influences internal control. Additionally, according to the research of Bramasto and Adiwiguna (2020), the use of an accounting system has little effect on EP, but internal control has a considerable effect on EP. Furthermore, Setyaningsih et al. (2021) discovered that AIS implementation, ICS implementation, and organizational culture all have a substantial impact on the quality of financial statements and performance. According to the findings of the study by Sagala (2020), AIS and internal control affect EP. Hla and Teru (2015) argue that AIS is incredibly valuable to both firms and organizations since it aids in managerial decision making, internal controls, and financial report quality. According to the findings of a study by Gunawan and Nengzih (2023), perceived utility is affected by the quality of accounting information systems, the quality of accounting information, and the security of accounting information systems. Additionally, Widayani and Wijayanti (2022) found that perceived reputation has influence on AIS, but service quality has no influence on AIS; however, service quality does have an influence on AIS that are moderated by purchasing decisions. The findings of Jarrah et al. (2023) indicate that the development of Jordanian banks' improved AIS performance is statistically influenced by communication technology networks.

According to the findings of the study by Sodiq et al. (2022), service quality, commitment, and the quality of AIS all have a simultaneous influence on community satisfaction. Internal audits, according to Jarrah et al. (2022a), help to mitigate the effects of creative accounting in Jordanian Islamic banks. The results of a study by Alnajjar (2017) demonstrate that top management support and understanding of accounting managers have significant influence on AIS in organizations, and that AIS have significant impact on performance management and organizational performance. Alzoubi (2011), on the other hand, discovered that adding AIS to the ERP system enhanced internal control and accounting output quality in companies. SQ, IQ, and SQ are crucial elements of AIS' success in enhancing organizational performance, according to the findings of Ali et al. (2016). A statistically significant correlation between internal audits and the supply chain was found by Jarrah et al. (2022b). Additionally, Ladan Shagari et al. (2017) found that the effectiveness of AIS was significantly influenced by the quality of the information and the system. The research of Jarrah and Almatarneh (2021) showed a strong correlation between the ways in which AIS elements affected organizational culture. According to Syah et al. (2019), application of AIS had a favorable and significant impact on EP. According to Olufunmilayo and Hannah (2018), ICS has a considerable impact on the EP of small-scale manufacturing businesses.

## 6. Implications and Limitations and Future Research and Conclusions

This study's objective was to determine how ICS influences the link between AIS and EP in Jordanian Islamic banks. Furthermore, the study contributes a new paradigm that incorporates ICS mediation's influence on the AIS-EP relationship. The role of the AIS in the development of EP in these Islamic banks is stressed in the second contribution.



Furthermore, the research investigates ICS as a bridge between AIS and EP in Jordanian Islamic Banks, as represented by “IQ, SQ1, and SQ2”.

The findings showed that there is a statistically significant correlation between AIS and EP. A statistically significant association between the ICS and the relationship between the AIS and EP in Jordanian Islamic Banks was also found, according to the data. The results of this study are in line with those of previous studies by (Susanto 2016; Al Hanini 2015; Maharani and Damayanthi 2020; Bramasto and Adiwiguna 2020; Setyaningsih et al. 2021; Sagala 2020; Hla and Teru 2015; Alzoubi 2011). Where internal controls are mostly focused on bank AIS, the primary method of moving financial data within a bank, internal controls allow managers to track and measure the impact of their accounting operations on EP, and the benefits of AIS can be quantified in terms of how they improve decision making, accounting data quality, performance evaluation, internal controls, and the ease with which bank transactions can be processed (Soudani 2012). The impact of AIS on the effectiveness of accounting control in banks is particularly evident in their ability to generate accurate, up-to-date, complete, and comparable data (Qatawneh 2012).

As a result, any bank's AIS must contain a method for monitoring and controlling data until system users provide accurate reports. During the creation of the AIS, the bank collaborates closely with system designers until they are convinced that the control and safety requirements are acceptable and sufficient, and that the entry of computers into the information system has a positive effect on the control and safety of data. Similarly, any AIS's qualitative attributes can be maintained if an adequate internal control mechanism is in place. The adaptability of internal controls has an impact on operations and management in every AIS scenario, which in turn has an impact on ICS. To support flawless AIS, an Islamic bank's ICS must also be adequate.

Even though it makes several significant contributions, this study has major drawbacks, and accepting these constraints adds to the credibility of the present research findings. To maintain a fair viewpoint in the diagnostic and interactive utilization of the model in Jordanian Islamic banks, the current study focused on just 92 employers, in order to concentrate on using AIS in Islamic Banks. As a result, results might be more accurate if there are more Islamic bank responses. Three AIS components were the focus of the recent study. Additionally, an additional study should be carried out in the future on the effects of AIS on the performance of Islamic banks in Jordan; other AIS features include dependability, relevance, and verifiability. As well as other mediating variables such as organizational commitment and organizational performance and the use of statistical tools, we were able to create a linear regression model, leading to some novel implications for the government and other industries. The present study also recommends that banks focus on ICS activation because of its positive effects on boosting EP and providing value for target attainment. As a result, the current work may serve as a foundation for later studies that increase field knowledge. As was previously mentioned, the most recent study contradicted certain conclusions from earlier research while supporting others. The shortcomings of the present study, however, can be overcome in further investigations.

**Author Contributions:** Conceptualization, B.A.F.J., M.F.M.A.-J. and A.M.A.B.; Data curation, Z.A.; Formal analysis, A.M.A.B.; Funding acquisition, B.A.F.J. and Z.A.; Investigation, M.F.M.A.-J. and Z.A.; Methodology, B.A.F.J.; Project administration, M.F.M.A.-J.; Resources, N.Z.; Software, B.A.F.J., N.Z., A.M.A.B. and M.F.M.A.-J.; Supervision, B.A.F.J. and N.Z.; Validation, N.Z.; Writing—original draft, B.A.F.J. and M.F.M.A.-J.; Writing—review & editing, A.M.A.B. and N.Z. All authors have read and agreed to the published version of the manuscript.

**Funding:** This research received no external funding.

**Institutional Review Board Statement:** Not applicable.

**Informed Consent Statement:** Informed consent was obtained from all subjects involved in the study.

**Data Availability Statement:** The accompanying authors are willing to provide the information that backs up the study's conclusions upon reasonable request.

**Conflicts of Interest:** The authors declare no conflict of interest.

## References

- Abd Aziz, Mohamad Azizal, Hilmi Ab Rahman, Md Mahmudul Alam, and Jamaliah Said. 2015. Enhancement of the accountability of public sectors through integrity system, internal control system and leadership practices: A review study. *Procedia Economics and Finance* 28: 163–69. [CrossRef]
- Akdere, Mesut, Mehmet Top, and Sabahattin Tekingündüz. 2020. Examining patient perceptions of service quality in Turkish hospitals: The SERVPERF model. *Total Quality Management & Business Excellence* 31: 342–52. [CrossRef]
- Al Hanini, Eman. 2015. Evaluating the Reliability of the Internal Control on the Computerized Accounting Information Systems: An Empirical Study on Banks Operating in Jordan. *Environment* 4: 6.
- Alawaqleh, Qasim Ahmad. 2021. The Effect of Internal Control on Employee Performance of Small and Medium-Sized Enterprises in Jordan: The Role of Accounting Information System. *The Journal of Asian Finance, Economics and Business* 8: 855–63. [CrossRef]
- Albashaheh, Aisar Ayed Nahar, Modafar Nayel Alhroob, Belal Eid Irbihat, and Sarfaraz Javed. 2018. Impact of accounting information system in reducing costs in Jordanian banks. *International Journal of Research-Granthaalayah* 6: 210–15. [CrossRef]
- Al-Dmour, Ahamed, Khaled Mofawiz Al-Fawaz, Rand Al-dmour, and Nurah Musa Allozi. 2017. Accounting information system and its role on business performance: A theoretical study. *Journal of Management and Strategy* 8: 79–87. [CrossRef]
- Ali, B. J., Wan Ahmad Wan Omar, and Rosni Bakar. 2016. Accounting Information System (AIS) and organizational performance: Moderating effect of organizational culture. *International Journal of Economics, Commerce and Management* 4: 138–58.
- Almatarneh, Zeyad, Jarah Baker Akram Falah, and Mufleh Amin AL Jarrah. 2022. The role of management accounting in the development of supply chain performance in logistics manufacturing companies. *Uncertain Supply Chain Management* 10: 13–18. [CrossRef]
- Alnajjar, Mohd I. M. 2017. Impact of accounting information system on organizational performance: A study of SMEs in the UAE. *Global Review of Accounting And Finance* 8: 20–38. [CrossRef]
- Al-Zaqeba, Murad Ali Ahmad, Jarah Baker Akram Falah, Inezeh Nehad Ibrahim, Almatarneh Zeyad, and AL Jarrah Mufleh Amin. 2022. The effect of management accounting and blockchain technology characteristics on supply chains efficiency. *Uncertain Supply Chain Management* 10: 973–82. [CrossRef]
- Alzoubi, Ali. 2011. The effectiveness of the accounting information system under the enterprise resources planning (ERP). *Research Journal of Finance and Accounting* 2: 10–19.
- Al-Zoubi, Abdullah M. 2017. The Extent of Electronic Accounting Information Systems' Ability to Provide Quantitative Indicators of Financial Performance in both Public and Private Universities in Jordan. *International Journal of Academic Research in Accounting, Finance and Management Sciences* 7: 97–107. [CrossRef] [PubMed]
- Anderson, James C., and David W. Gerbing. 1988. Structural equation modeling in practice: A review and recommended two-step approach. *Psychological Bulletin* 103: 411–23. [CrossRef]
- Anitha, Jagannathan. 2014. Determinants of employee engagement and their impact on employee performance. *International Journal of Productivity and Performance Management* 63: 308–23.
- Bani Ahmad, Ahmad. 2022. Empirical Analysis on Accounting Information System Usage in Banking Sector in Jordan. Available at SSRN 4241257. Available online: <https://www.abacademies.org/articles/Empirical-Analysis-on-Accounting-Information%20System-Usage-in-Banking-Sector-in-Jordan-1528-2635-23-5-454.pdf> (accessed on 20 February 2023).
- Binh, Vu Thi Thanh, Nhat-Minh Tran, and Manh-Chien Vu. 2022. The effect of organizational culture on the quality of accounting information systems: Evidence from Vietnam. *SAGE Open* 12: 21582440221121599. [CrossRef]
- Bramasto, Ari, and Ridwan Hana Adiwiguna. 2020. The Effect of The Implementation of Accounting Information Systems and Internal Control on Employee Performance. *JASa. Jurnal Akuntansi, Audit dan Sistem Informasi Akuntansi* 4: 328–37. [CrossRef]
- Bukenya, Moses. 2014. Quality of accounting information and financial performance of Uganda's public sector. *American Journal of Research Communication* 2: 183–203.
- Burgos, Chrisha P., Irish S. Namoc, Jasmeren P. Padilla, and Joe Mari N. Flores. 2022. The Influence of Accounting Information System on the Organizational Performance Among SMEs in Tagum City. *International Journal of Multidisciplinary: Applied Business and Education Research* 3: 781–90. [CrossRef]
- Dandago, Kabiru I., and Abdullahi Sani Rufai. 2014. Information technology and accounting information system in the Nigerian banking industry. *Asian Economic and Financial Review* 4: 655–70.
- Diamantidis, Anastasios D., and Prodromos Chatzoglou. 2019. Factors affecting employee performance: An empirical approach. *International Journal of Productivity and Performance Management* 68: 171–93. [CrossRef]
- Fakhimuddin, Muhammad. 2018. Reconsidering Accounting Information Systems: Effective Formulations for Company's Internal Control. *Arthatama* 2: 26–34.
- Fitriati, Azmi, and Sri Mulyani. 2015. The influence of leadership style on accounting information system success and its impact on accounting information quality. *Research Journal of Finance and Accounting* 6: 167–73.
- Gaur, Ajai S., and Sanjaya S. Gaur. 2006. *Statistical Methods for Practice and Research: A Guide to Data Analysis Using SPSS*, 1st ed. Thousand Oaks: Sage.
- Gorla, Narasimhaiah, Toni M. Somers, and Betty Wong. 2010. Organizational impact of system quality, information quality, and service quality. *The Journal of Strategic Information Systems* 19: 207–28. [CrossRef]

- Gunawan, Sri, and Nengzih Nengzih. 2023. The Influence of Accounting Information System Quality, Accounting Information Quality and Accounting Information System Security on End User Satisfaction of S4/Hana System Application Product (SAP) with Perceived Usefulness as a Moderating Variable at PT Hakaaston. *Saudi Journal of Economics and Finance* 7: 22–32.
- Hair, Joseph F., Jr., Marko Sarstedt, Christian M. Ringle, and Siegfried P. Gudergan. 2017. *Advanced Issues in Partial Least Squares Structural Equation Modelling*. Los Angeles: Sage.
- Hameed, Abdul, and Aamer Waheed. 2011. Employee development and its affect on employee performance a conceptual framework. *International Journal of Business and Social Science* 2: 224–29.
- Hla, Daw, and Susan Peter Teru. 2015. Efficiency of accounting information system and performance measures. *International Journal of Multidisciplinary and Current Research* 3: 976–84.
- Jarah, Baker Akram Falah, and Mufleh Amin AL Jarrah. 2022. The role of accounting information systems (AIS) in increasing performance efficiency (IPE) in Jordanian companies. *Academy of Strategic Management Journal* 21: 111.
- Jarah, Baker Akram Falah, and Takiah Binti Mohd Iskandar. 2019a. The Mediating Effect of Acceptance of Using AIS on the Relationship between the Accounting Information Systems and Financial Performance in Jordanian Companies. *International Journal of Research and Innovation in Social Science (IJRISS)* 3: 256–63.
- Jarah, Baker Akram Falah, and Takiah Binti Mohd Iskandar. 2019b. The role of characteristics of accounting information systems in the improve the financial performance of Jordanian companies. *International Journal Of All Research Writings* 1: 32–45.
- Jarah, Baker Akram Falah, and Zeyad Almatarneh. 2021. The effect of the elements of accounting information system (AIS) on organizational culture (OC)-A field study. *Academy of Strategic Management Journal* 20: 1–10.
- Jarah, Baker Akram Falah, Mufleh Amin AL Jarrah, Murad Ali Ahmad Al-Zaqeba, and Mefleh Faisal Mefleh Al-Jarrah. 2022a. The Role of Internal Audit to Reduce the Effects of Creative Accounting on the Reliability of Financial Statements in the Jordanian Islamic Banks. *International Journal of Financial Studies* 10: 60. [\[CrossRef\]](#)
- Jarah, Baker Akram Falah, Mufleh Amin AL Jarrah, and Murad Ali Ahmad Al-Zaqeba. 2022b. The role of internal audit in improving supply chain management in shipping companies. *Uncertain Supply Chain Management* 10: 1023–28. [\[CrossRef\]](#)
- Jarah, Baker Akram Falah, Mufleh Amin AL Jarrah, Salam Nawaf Almomani, Emran AlJarrah, and Maen Al-Rashdan. 2023. The effect of reliable data transfer and efficient computer network features in Jordanian banks accounting information systems performance based on hardware and software, database and number of hosts. *International Journal of Data and Network Science* 7: 357–62. [\[CrossRef\]](#)
- Khan, Hajera Fatima. 2016. Accounting Information System: The Need of Modernization. *International Journal of Management and Commerce Innovations* 4: 4–10.
- Ladan Shagari, Shamsudeen, Akilah Abdullah, and Rafeah Mat Saat. 2017. Accounting information systems effectiveness: Evidence from the Nigerian banking sector. *Interdisciplinary Journal of Information, Knowledge, and Management* 12: 309–35. [\[CrossRef\]](#)
- Maharani, Pande Putu Gayatri, and I. G. A. E. Damayanthi. 2020. The effect of accounting information systems and internal control of employee performance with organizational culture as a mediation variable. *American Journal of Humanities and Social Sciences Research (AJHSSR)* 4: 233–41.
- Matovu, Bakisa Harriet. 2011. Perceived Quality of Accounting Information and Performance of Small and Medium Enterprises (SMEs). Doctoral dissertation, Makerere University, Kampala, Uganda.
- Napitupulu, Ilham Hidayah. 2020. Internal Control, Manager's Competency, Management Accounting Information Systems and Good Corporate Governance: Evidence from Rural Banks in Indonesia. *Global Business Review*. [\[CrossRef\]](#)
- Neogy, Taposh Kumar. 2014. Evaluation of efficiency of accounting information systems: A study on mobile telecommunication companies in Bangladesh. *Global Disclosure of Economics and Business* 3. [\[CrossRef\]](#)
- Nugroho, Muchamad Aqil. 2019. Analysis of internal control of inventory accounting information system at pt. ANDRE LAURENT. *Dinasti International Journal of Education Management And Social Science* 1: 73–86. [\[CrossRef\]](#)
- Olufunmilayo, Adedeji Abosede, and Olubodun Opeyemi Hannah. 2018. Effect of Internal Control System on Employee Performance of Small-Scale Manufacturing Enterprises in Ondo State, Nigeria. *Human Resource Research* 2: 48–60. [\[CrossRef\]](#)
- Onaolapo, A. A., and T. A. Odetayo. 2012. Effect of accounting information system on organisational effectiveness: A case study of selected construction companies in Ibadan, Nigeria. *American Journal of Business and Management* 1: 183–89. [\[CrossRef\]](#)
- Qatawneh, Adel M. 2012. The effect of electronic commerce on the accounting information system of Jordanian banks. *International Business Research* 5: 158. [\[CrossRef\]](#)
- Ranganath, Malitha, and Nadarajah Rajeshwaran. 2022. Quality of accounting information systems and organizational effectiveness in an emerging country. *SMART Journal of Business Management Studies* 18: 22–29. [\[CrossRef\]](#)
- Romney, Marshall, and Barry Steinbart. 2006. *Accounting Information Systems*, 10th ed. Hoboken: Prentice Hall International Inc.
- Sabri, Syamimi Nabilah, Nor Hanani Ahamad Rapani, and Oday Jasim Almaliki. 2022. The Accounting Information System (AIS) Effectiveness and SMEs Performance: A Conceptual Paper. *Management Research Journal* 11: 64–73.
- Saeidi, Hadi, and Bhavani Prasad. 2014. Impact of accounting information systems (AIS) on organizational performance: A case study of TATA consultancy services (TCS)-India. *Journal of Management and Accounting Studies* 2: 54–60. [\[CrossRef\]](#)
- Sagala, Friska Zagita. 2020. The Effect of Accounting Information Systems and Internal Control of Employee Performance. *JASa (Jurnal Akuntansi, Audit dan Sistem Informasi Akuntansi)* 4: 69–81. [\[CrossRef\]](#)
- Salehi, Mahdi, Mahmoud Mousavi Shiri, and Fatemeh Ehsanpour. 2013. Effectiveness of internal control in the banking sector: Evidence from bank Mellat, Iran. *IUP Journal of Bank Management* 12: 23–34.

- Sekaran, Uma, and Roger Bougie. 2016. *Research Methods for Business: A Skill-Building Approach*, 5th ed. New York: John Wiley & Sons Inc.
- Setyaningsih, S. D., S. Mulyani, B. Akbar, and Ida Farida. 2021. Implementation and Performance of Accounting Information Systems, Internal Control and Organizational Culture in the Quality of Financial Information. *Utopía y Praxis Latinoamericana: Revista Internacional de Filosofía Iberoamericana y Teoría Social* 26: 222–36.
- Shahzadi, Irum, Ayesha Javed, Syed Shahzaib Pirzada, Shagufta Nasreen, and Farida Khanam. 2014. Impact of employee motivation on employee performance. *European Journal of Business and Management* 6: 159–66.
- Sodiq, Dinar Irfani, Hadi Samanto, and Sri Laksmi Pardanawati. 2022. The influence of quality of service, commitment and quality of accounting information systems on community satisfaction (Survey in Kalikotes District, Klaten Regency). *International Journal of Economics, Business and Accounting Research (IJEBAR)* 6: 1869–70.
- Soudani, Siamak Nejadhosseini. 2012. The usefulness of an accounting information system for effective organizational performance. *International Journal of Economics and Finance* 4: 136–45. [\[CrossRef\]](#)
- Susanto, Azhar. 2016. The effect of internal control on accounting information system. *International Business Management* 10: 5523–29. [\[CrossRef\]](#)
- Syah, L. Y., S. N. Nafsiah, and K. Saddhono. 2019. Linear regression statistic from accounting information system application for Employee integrity. In *Journal of Physics: Conference Series*. Bristol: IOP Publishing, vol. 1339, p. 012131.
- Teru, Susan Peter, Innocent Idoku, and Jane Tinyang Ndeyati. 2017. A review of the impact of accounting information system for effective internal control on firm performance. *Indian Journal of Finance and Banking* 1: 52–59. [\[CrossRef\]](#)
- Widyani, Rachma, and Ajeng Wijayanti. 2022. Effect of Perceived Reputation and Service Quality on Accounting Information Systems that Moderate Purchase Decisions. *Journal Research of Social, Science, Economics, and Management* 1: 1870–77. [\[CrossRef\]](#)
- Wongsim, Manirath, and Pawornprat Hongsakon. 2015. The Adoption of Process Management for Accounting Information Systems in Thailand. *World Academy of Science, Engineering and Technology, International Journal of Computer, Electrical, Automation, Control and Information Engineering* 9: 1327–35.
- Zuo, Zhigang, and Zhibin Lin. 2022. Government R&D subsidies and firm innovation performance: The moderating role of accounting information quality. *Journal of Innovation & Knowledge* 7: 100176.

**Disclaimer/Publisher's Note:** The statements, opinions and data contained in all publications are solely those of the individual author(s) and contributor(s) and not of MDPI and/or the editor(s). MDPI and/or the editor(s) disclaim responsibility for any injury to people or property resulting from any ideas, methods, instructions or products referred to in the content.