



Effect of Corona-virus Disease 2019 (COVID-19) and Inflation Rate on the Foreign Exchange Rate in Kenya

**Kenga, Dominic Shukrani ^{a*}, Kamau, Charles Guandaru ^a
and Amayo, Sylvia Akinyi ^b**

^a *Department of Accounting and Finance, Technical University of Mombasa, P.O.Box 90420 (80100),
Mombasa, Kenya.*

^b *Kenya Bankers Association, P.O.Box 73100 (00200), Nairobi, Kenya.*

Authors' contributions

This work was carried out in collaboration among all authors. All authors read and approved the final manuscript.

Article Information

DOI: 10.9734/AJEBA/2022/v22i1430620

Open Peer Review History:

This journal follows the Advanced Open Peer Review policy. Identity of the Reviewers, Editor(s) and additional Reviewers, peer review comments, different versions of the manuscript, comments of the editors, etc are available here: <https://www.sdiarticle5.com/review-history/86953>

Original Research Article

Received 02 March 2022

Accepted 03 May 2022

Published 06 May 2022

ABSTRACT

The general objective of this research was to investigate the effect of COVID-19 and Inflation rate on the Foreign Exchange rate in Kenya. Census technique was used in collecting a 263 days data from the World Health Organization, Central Bank of Kenya and the Kenya National Bureau of Statistics. Analysis of data was through quantitative techniques, inferential analysis; specifically, correlation analysis was conducted. Overall model fitness test was through F-test. The coefficients generated from the regression model were used to test the hypothesis. Correlation results indicated a significant positive relationship between COVID-19 and inflation rate against the foreign exchange rate. Hypothesis testing at 5% level of significance established a significant effect on COVID-19 and Inflation rate with the foreign exchange rate, hence rejecting H_{01} and H_{02} . It was concluded that COVID-19 and Inflation rate significantly affect the Foreign Exchange rate in Kenya, hence requiring a close monitoring, proper policy formulation and mitigation measures. For further studies, we proposed that another study may be conducted to cover current emerging issues which may affect the foreign exchange rate in Kenya and the economy at large.

Keywords: *Corona-virus disease 2019 (COVID-19); World Health Organization (WHO); Foreign exchange rate; Kenya Shilling (KES); United States Dollar (USD).*

1. INTRODUCTION

The novel Coronavirus disease 2019 (COVID-19) similarly stated as Severe Acute Respiratory Syndrome Coronavirus 2 (SARS-CoV-2) is deemed as an adverse human-social and economic crisis that has hit hard and threatened to a greater extent the existence of the human race in the recent times [1]. COVID-19 is a respiratory disease which affects the respiratory systems; it is transmitted between people through respiratory droplets and contacts routes [2]. COVID-19 infection was initially reported in December 2019 in Wuhan; the 7th largest city in China, and later on declared a pandemic due to its rapid globalization [3].

The World Health Organization (WHO) declared COVID-19 as a “global health emergency” for the first time in January 2020; on March 11 it officially declared the viral outbreak as a global pandemic, the highest level of health emergency [2]. Since then, the emergency “evolved into a global public health and economic crisis that affected the \$90 trillion global economy beyond anything experienced in nearly a century” [4].

Immediately, the World Health Organization (WHO) instituted measures that the public ought to observe in quest to curb the rapid spread and infection of COVID-19 [4]. These measures included, however not limited to: washing hands regularly with soap and running water, or sanitizing with an alcohol based hand sanitizer, maintaining social distance of between one to two meters when in public places and practicing physical distancing by avoiding unnecessary travels, avoiding touching your face, staying at home when feeling unwell, refraining from smoking or any other activities that strain and weaken the lungs, covering your mouth and nose when coughing or sneezing [2].

1.1 Statement of the Problem

The measures instituted to curb the spread of COVID-19, came with their equal measures of adverse effect on the economies of the world (Lelissa, 2020) For instance as the numbers of reported cases upsurged, governments resorted to curfews, lock-downs, travel restriction and closing of borders. China was the first country to enforce the quarantine and lockdown in its cities, and afterwards as the pandemic kept on

escalating and more people getting infected, other countries in Europe, United States of America (USA), Asia and Africa followed suite, thus resulting to far-reaching economic cost burden to the countries of the world [3].

Major effects brought by the pandemic were significant drop in income levels, a increase in unemployment, and disruptions in the transportation, service, and manufacturing industries [5]. The COVID-19 global recession is the most severe since the culmination of World War II. “The global economy contracted by 3.5 percent in 2020” according to the April 2021 World Economic Outlook Report published by the IMF, a 7 percent loss relative to the 3.4 percent growth forecast back in October 2019 [6]. While virtually every country covered by the IMF posted negative growth in 2020, the downturn was more pronounced in the poorest parts of the world [7].

In Kenya, according to the ministry of health of Kenya and the World Health Organization (WHO), the first case of COVID-19 was reported on 13th March 2020 [2]. Since that day, the numbers kept on increasing and as of 30th November 83,618 people had been confirmed infected with the virus [2]. This compelled the government of Kenya to shut down learning institutions, enforce curfews as well as partial lock down of some counties which exhibited high numbers of COVID-19 infection, which included Nairobi and Mombasa Counties. These measures undertaken by the government of Kenya, similar to other countries affected the economy of the country enormously as a result of in-activities and slowed business transactions and consequently, many people lost jobs, salaries were slashed down, the tourism industry was almost paralyzed as hotels and all social gathering places were closed.

During this period of COVID-19 under study, between 13th March 2020 to the date of undertaking this research study 30th November 2020, the overall Consumer price Index (CPI) deflected from 107.475 in March 2020 to 110.78 in November 2020 [8]. The unemployment rate rose to 2.65% as at December 2020 [9]. The Kenyan Shilling (KES) faced extensive pressure against the United States Dollar (USD) due to limited exports, low tourism activities, and general law business transaction during this period, and as a result the Kenyan Shilling (KES)

deflected from 102.4235 on 13th March 2020 to 110.0535 on 30th November 2020 [10]. The aforementioned occurrences, triggered and motivated this research study, so as to investigate the effect of COVID-19 and Inflation rate on the Foreign Exchange rate in Kenya, (holding other factors which may affect the foreign exchange rate constant (*ceteris paribus*)).

So far, substantial researches have been conducted since the outbreak of the novel Coronavirus COVID-19, for instance Barua [3] conducted a research study on understanding Coronanomics: The Economic implications of the corona virus (COVID-19) pandemic, in Dhaka-Bangladesh and concluded that: COVID-19 is endangering economies and that, the end to this pandemic remains tentative and it is causing loss of civic assurance globally. Barua [3] further postulates that, recovering from this pandemic stands paramount and economic recovery is ancillary. Nonetheless, as indications of economic adversities transpire, it would be prudent to instigate designing and executing robust as well as inventive action plans with a long-run perspective so as to thwart the impending calamities, otherwise, it might be too late and an economic depression may be inevitable [3].

In Denmark, using bibliometric analysis approach Surabhi [1] investigated on the COVID-19 emerging trends in the field of business and management, and concluded that: COVID-19 will be the catalytic agent of varied long-term and short-term strategy vicissitudes and would require theoretical and empirical responsiveness of scholars.

In Guangxi University China, using simple regression analysis in double log and semi log Linear models to reconnoiter the impact of COVID-19 on the financial markets in China and USA, Sansa [11] found a positive significant association amid COVID-19 confirmed cases and all the financial markets (Shanghai stock exchange and New York Dow Jones) In Ethiopia, Using input-output framework in determining the impact of COVID-19 on the Ethiopian Private Banking System, Lelissa (2020) found that COVID-19 has an effect on the Ethiopian private banks' balance sheet and income statements.

This current research study narrows down to Kenya and investigates the effect of COVID-19 and Inflation rate on the foreign exchange rate in Kenya.

1.2 Significance of the Study

This study aims at generating a model which will be of tremendous value to the Kenyan government and policy makers such as the Kenya National Bureau of statistics (KNBS), Central bank of Kenya (CBK), the ministry of health of Kenya, other parastatals, partisan organizations, as well as the general public, with regard to the effect of COVID-19 and Inflation rate on the Foreign Exchange rate in Kenya.

The research work will also form a base for forthcoming studies pertaining to the novel COVID-19 pandemic and its effect on varied governments and institutions; it will open up new areas and arouse the curiosity of academicians, scholars and researchers in trying to dig deeper in this field so as to fill the research gaps.

1.3 Objective & Hypothesis of the Study

The general objective of the study was to investigate the effect of COVID-19 and Inflation rate on the Foreign Exchange rate in Kenya. The null hypothesis was used in carrying out the study which investigated the effect of COVID-19 and Inflation rate on the Foreign Exchange rate in Kenya, and it was stated in the following manner.

H₀₁: COVID-19 has no significant effect on the Foreign Exchange rate in Kenya.

H₀₂: Inflation rate has no significant effect on the Foreign Exchange rate in Kenya.

1.4 Scope of the Study

The study was undertaken for the period raging from 13th March 2020 to 30th November 2020, with data collected from the ministry of health of Kenya, the World Health Organization (WHO), the Central Bank of Kenya (CBK) and the Kenya National Bureau of Statistics (KNBS), for the study which investigated the effect of COVID-19 and Inflation rate on the Foreign Exchange rate in Kenya.

1.5 Limitation of the Study

We acknowledge that there are other several factors which affect the Foreign Exchange rate (USD/KES) in Kenya such as policies by the government, the exchequer, the levels of exports and imports in the country, money supply in the

economy among others. However in carrying out this research and in order to investigate the effect of COVID-19 and Inflation rate on the Foreign Exchange rate in Kenya, all other factors affecting the foreign exchange rate in Kenya were held constant.

2. LITERATURE REVIEW

Literature by an assortment of scholars with respect to the COVID-19 pandemic, the Inflation rate and the USD/KES exchange rate were reviewed. The theoretical review covered the effect of COVID-19 and Inflation rate on the Foreign Exchange rate in Kenya and their exploratory variables which culminated in the development of the conceptual framework which guided this research. The subsequent section presented the empirical review of previous researches by various scholars and their findings. Finally, the section critically assessed the existing literature, and gave an analysis of the research gap.

2.1 Theoretical Framework

Theories are sets of interconnected constructs or concepts, definitions and propositions which bring-forward logical scrutiny of occurrences through specifying relationships amid factors, with the rationale of elucidating and forecasting phenomena [12].

2.1.1 COVID-19

Corona-virus disease (COVID-19) erupted towards the end of 2019; it is a viral disease transmitting between animals and people, causing illness ranging from common cold to severe acute respiratory syndrome [2]. COVID-19 erupted in Wuhan, China towards the end of 2019, and subsequently avowed a Pandemic by the WHO, due to its swift globalization [3] As at 7th December 2020, a total of 66,422,058 people were reported to have contacted COVID-19 cumulatively, while 1,532,418 people were reported to have succumbed and died of COVID-19 globally [2]. Here in Kenya, according to the ministry of health and the WHO data, a total of 88,380 people had been infected with COVID-19 and 1,526 people had died of COVID-19 as of 6th December 2020 [2].

At first, China was the epicenter of COVID-19, with a high number of infections and mortality cases, however that relocated rapidly to Europe making Italy the subsequent epicenter of the

novel Corona virus disease. At the latest, as at 30th November, 2020 the US topped the list with over 13,541,221 confirmed cases of COVID-19, making the United States the latest epicenter of the pandemic [2].

As the numbers of COVID-19 infection increased, and the stringent measures employed to curb the spread of this disease, economies of the world were put under great distress and an economic crisis almost comparable to the great financial crisis of 2007-2008 [11].

Kenya as a country experienced its equal measure of economic hurts as expressed in the distressed Kenyan Shilling (KES) against the United States Dollar (USD), making it to deflect from 102.4235 on 13th March 2020 to 110.0535 on 30th November 2020 [10]. The distressed Kenyan Shilling (KES) against the USD, the worsening living standards due to unemployment and salary cuts, the consumer price indices deflected from 107.475 in March 2020 to 110.78 in November 2020 [8], affected the economy of Kenya to a greater extent and consequently motivated this research study so as to investigate the effect of COVID-19 on the Foreign Exchange rate in Kenya. In this study, the daily confirmed cases of COVID-19 infections in Kenya formed one of the independent variable.

2.1.2 The monetarism theory

Inflation is the overall increase in price levels of goods and services, resulting from amplified demand or due to amplified import prices [13]. The monetarism theory was initially hypothesized by Cagan in the 1960s who looked at inflation as being instigated by financial expansion; he postulated that prospects of imminent inflation rate depend on preceding inflation rates. Cagan [14] looked at inflation as a consequence of amplified money supply in a country and concluded that inflation takes place if money supply growth in a country supersedes the economic growth [14].

The monetarism theory elucidates demand pull inflation as instigated by superfluous demand for merchandises as well as amenities which results to an affirmative output gap, as a result, businesses react by rising prices to upsurge profits [14]. This attributes to rise in money supply in the system, depreciation of the exchange rate and reduction in tax rates in the country. Monetarism holds the opinion that

inflation is as a result of higher money supply growth from the rate of economic growth, designed at regulating the amount, charge, distribution of funds as well as credit in the entire economy. Furthermore, it targets at realizing some intents of sustaining development and stability in the economy [14]. Consequently, any monetary policy pursues to stabilize the exchange rates and prices, elevate employment levels, steady economic development and smoothening the interest rate.

The Inflation rate in Kenya (CPI) has been deflecting since the day of confirmation of the first case of COVID-19 in the country, for example, it deflected from 107.4700 in March 2020 to 110.7800 in November 2020 [8]. The deflection in the inflation rate (CPI), triggered the close study of the monetarism theory so as to support one of the independent variables, Inflation rate (CPI) in the quest to investigate the effect of COVID-19 and Inflation rate on the Foreign Exchange rate in Kenya.

2.1.3 The purchasing power parity theory (PPPT)

The Purchasing Power Parity Theory (PPPT) is an exchange rate fortitude concept, it relates to mean product prices amid economies, Muchiri [15] holds that; exchange rate is probable to be convectional at the equity point amid the purchasing powers of the monies of dual legal tenders which are inconvertible. The (PPPT)

suggests that discrepancies in exchange rate are prompted by disparities in inflation rate [15].

In accordance with the PPPT, when Inflation rate of an economy rises relative to another one, amplified imports as well as declined exports diminishes the high Inflation legal tender as a result of worsening current and trade account balances. PPPT theory helps as a standard of determining rate of exchange equilibrium [15].

From the day of the first case of COVID-19 confirmation in Kenya, the rate of exchange between the Kenyan shilling (KES) and United States Dollar (USD) has been fluctuating to a greater extent. For instance the USD/KES exchange rate deflected from 102.4235 on 13th March 2020 to 110.0535 on 30th November 2020 [10]. These deflections in the exchange rate during the COVID-19 pandemic epoch, motivated the intimately study of the PPPT theory in quest to investigate the effect of COVID-19 and Inflation rate on the Foreign Exchange rate in Kenya.

2.2 Conceptual Framework

Conceptual framework is a diagrammatic illustration depicting the affiliation amid dependent and independent variables; it is the researcher's elucidation on how the study would be undertaken [16]. The conceptual framework which guided this research study was developed in the following manner:

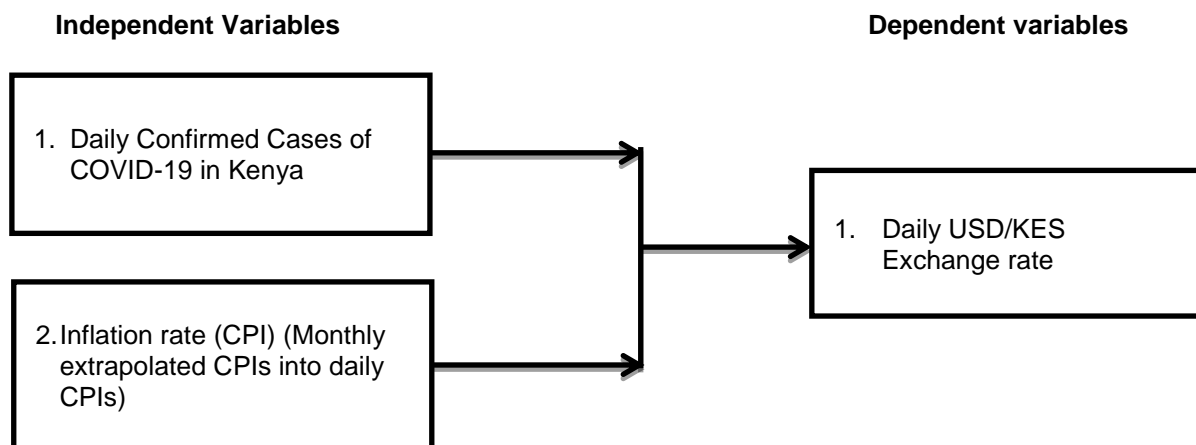

Fig. 1. Conceptual framework
Source: Author

2.3 Review of Literature on Study Variables

Literature with regard to daily confirmed cases of COVID-19 in Kenya and the Inflation rate as the independent variables and the USD/KES exchange rate as the dependent variables were reviewed so as to study the effect of COVID-19 on the Foreign Exchange rate in Kenya.

2.3.1 Daily confirmed cases of COVID-19

Since its eruption, COVID-19 has been upsurging and spreading so fast, making the World Health Organization (WHO) to declare it as a pandemic [2]. As at 7th December 2020, the world recoded a total of 66,422,058 confirmed cases of COVID-19 infections, out of these 1,532,418 people had succumbed and died of this disease [2]. The United States of America leads with a total of 28,355,791 confirmed cases, followed by Europe with a total of 20,154,730 confirmed cases, followed by South East-Asia with a total of 11,114,545, while Africa had a total of 1,556,168 [2].

Out of the COVID-19 total cumulative confirmed cases in Africa as at 7th December 2020, 88,579 were from Kenya, and according to the ministry of Kenya and the World Health Organization (WHO) data, as at 7th December 2020 1,531 people had succumbed and died of COVID-19 in Kenya. As the numbers of COVID-19 infections kept on rising, fear engulfed the people, stringent measures enacted by the government of Kenya so as to curb the spread of the disease also kept on hurting the economy in varied instances. These escalating numbers of COVID-19 cases motivated this research so as to investigate how the daily confirmed cases of COVID-19 affects the Foreign Exchange rate in Kenya.

2.3.2 Inflation rate (CPI)

Inflation is an unrelenting and appreciable rise in the general price levels of goods and services; it is a rate which measures levels of price fluctuation using a given index [15]. The universally recognized index for measuring inflation is the Consumer Price Index (CPI) which determines average vends cost incurred by final consumers. Escalating CPI designates presence of inflation. High prices which portray an increase in inflation tend to decrease general consumer expenditure which eventually culminates to a reduction in Gross Domestic Product (GDP). Rapidly increase in inflation rates indicates the possibility of poor macroeconomic policies [15].

Inflation rate has been deflecting over the period since the day of confirmation of the first case of COVID-19 in Kenya, for instance, it deflected from 107.4700 in March 2020 to 110.7800 in November 2020 [8]. The deflection in the inflation rate (CPI), triggered this study in quest to investigate the effect of COVID-19 and Inflation rate on the Foreign Exchange rate in Kenya.

2.3.3 Foreign exchange rate (USD/KES)

Foreign exchange rate is the worth of binary currencies comparative one to another; it is the rate at which a particular legal tender is translated to the home currency [15]. It is the cost at which a country's legal tender may be converted to another country's currency. The Kenyan Shilling (KES) faced a lot of pressure against the United States Dollar (USD) due to limited exports, low tourism activities, and as a result the Kenyan Shilling deflected from 102.4235 on 13th March 2020 to 110.0535 on 30th November 2020 [10]. This deflection in the foreign exchange rate motivated this research study so as to investigate the effect of Covid-19 and Inflation on the Foreign exchange rate in Kenya.

Several studies with regard to how foreign exchange affected the Kenyan economy have been conducted, for instance, Mandela [17] carried out a study to investigate the effect of foreign exchange rate fluctuations on the export earnings of the coffee industry in Kenya and concluded that; fluctuations in exchange rates and Foreign Direct Investments as a percentage of the GDP largely affected coffee export earnings in Kenya.

In her study on the influence of foreign exchange rate fluctuations on the financial performance of commercial banks listed at the Nairobi securities exchange, Lagat (2016) found that there existed a strong positive relationship between foreign exchange rates and financial performance indicators. The study recommends that the Government should put up more measures to increase the country's exports so as to take care of foreign exchange fluctuations, which may hurt the economy when there is a demand for more foreign currency, thus depreciating the local currency.

2.3.4 Inflation rate, COVID-19 and foreign exchange rate

The level of inflation has a direct impact on the exchange rate between two currencies on

several levels [18]. The Purchasing power parity theory attempts to compare the different purchasing powers of each country according to the general price level. Changes in purchasing power parity (and therefore inflation) affect the exchange rate. Inflation affects exchange rate when it is higher in one country than in the other, thus the currency with the higher inflation rate loses value and depreciates, while the currency with the lower inflation rate appreciates on the Forex market [18].

The COVID-19 pandemic period of study has seen the consumer price indices in Kenya rising as the rate of COVID-19 infection increases. This period has witnessed the KES/USD exchange rate rising as the Kenya shilling depreciated against the US Dollar due to decrease in exports activities.

2.4 Empirical Review and Critic of Literature Reviewed

This segment presented a review of empirical studies by an assortment of researchers around the globe, who focused efforts in the study of COVID-19 pandemic, its effect as well as variables which affects the foreign exchange rates. Barua [3] conducted a research study on understanding Coronanomics: The Economic implications of the corona virus (COVID-19) pandemic, in Dhaka-Bangladesh and concluded that: COVID-19 is endangering economies and that, the end to this pandemic remains tentative and it is causing loss of civic assurance globally. Barua [3] further postulates that, recovering from the pandemic is paramount and economics is ancillary. Nonetheless, as indications of economic adversities transpire, it would be prudent to commence instituting and executing aggressive as well as innovative action plans with a long-run perspective so as to thwart the impending calamities, or, it might be too late and an economic depression may be inevitable [3].

In Denmark, using bibliometric analysis approach Surabhi [1] investigated on the COVID-19 emerging developments in business and management, and concluded that: COVID-19 will be the catalytic agent of varied long-term and short-term policy vicissitudes and would require hypothetical and experimental responsiveness of scholars.

In Guangxi University China, Sansa [11] investigated the impact of COVID-19 on the

financial markets in China and USA, and found a positive significant association amid COVID-19 confirmed cases and the Shanghai stock exchange and New York Dow Jones stock exchange. In Ethiopia, Using input-output framework in determining the impact of COVID-19 on the Ethiopian Private Banking System, Lelissa (2020) found that COVID-19 has an effect on the Ethiopian private banks' balance sheet and income statements.

Mert and Omer [19] researched on the impact of COVID-19 on emerging stock markets and concluded the impact of the outbreak had been highest in Asian emerging markets whereas emerging markets in Europe had experienced the lowest, during the period of investigation [19].

Muchiri [15] studied the effect of inflation and interest rates on the foreign exchange rates in Kenya and found a positive significant association amid inflation (CPI) and the foreign exchange rates and recommended that the government of Kenya and the Central Bank of Kenya (CBK) should employ existing monetary policies to control the rise in inflation rates. Kamau and Ilamoya [20] stated in their study that, COVID-19 is one of the disruptions that had major effect on accounting and financial reporting systems in Kenya.

Indrajit [21] examined the effect of COVID-19 on foreign exchange rate and stock market in India and found a positive correlation between the growth rate of COVID-19 confirmed cases and the growth rate of exchange rate. Using vector autoregressive (VAR) model over a sample period ranging from February 25, 2020 to May 6, 2021 Syed et al. [22] found that a shock to total daily coronavirus cases in Pakistan has a positive and significant impact on both the exchange rate and stock market.

In their paper, Banerjee et al. [23] on inflation at risk noted that a number of drivers of inflation have shifted dramatically as a result of the COVID-19 outbreak, for instance in April 2020, the IMF World Economic Outlook, for example, reported headline inflation falling by 0.9 and 0.4 percentage points below the 2019 level in Advanced Economies and emerging market and developing economies, respectively. Banerjee et al. [23] also noted that economic activities collapsed and oil prices fell sharply, and at the same time financial conditions tightened and

exchange rates in many emerging economies depreciated.

Shapiro [24] conducted a study on monitoring the inflationary effects of COVID-19, his findings were consistent with the findings of Leduc and Liu (2020), which showed that the recent drop in core PCE inflation was mainly attributable to large declines in consumer demand for goods and services stemming from COVID-19, which had more than offset any upward inflation pressures due to supply constraints in some sectors.

2.5 Research Gap

After a critical review of the literature in the previous section of this study, it was evident that the reviewed literature by the aforementioned researchers did not directly address the hypothesis regarding the effect of COVID-19 and Inflation on the Foreign Exchange rate in Kenya, which was the intension of this current study. For instance, most of the studies on COVID-19 were conducted outside Kenya, for example the study by Indrajit [21] was conducted in Pakistan while the study by Sansa [11] was done in China.

In terms of methodology, Surabhi [1] used bibliometric analysis approach in Denmark while investigating the emerging developments in business and management as a result of COVID-19.

This current study used regression analysis and was conducted in Kenya in the period ranging from March 2020 to November 2020.

3.3 Measurement of Variables

Table 1. Measurement of variables

Variables	Variables measurement approach
COVID-19	▪ Daily Confirmed cases of COVID-19
Foreign Exchange Rate	▪ Daily USD/KES Exchange rate
Interest Rate (CPI)	▪ Daily Consumer Price Indices (CPI) (Extrapolated from the Monthly CPI figures)

3.4 Data Processing and Analysis

The raw data gathered was confirmed to ensure completeness before running the Regression Analysis Model used in this study so as to generate tabulated reports, descriptive statistics, inferential statistics and the coefficients of regression. F-test was conducted so as to test the overall fitness of the model, and finally the regression coefficients from the Regression Analysis Model were interpreted and decision made whether to accept or reject the null hypothesis at 5% level of significance.

3. METHODOLOGY

The areas discussed in this section consisted of the study population, data collection tools and processes, measurement of variables, data processing and data analysis which culminated in the construction of the Regression Analysis Model.

3.1 Target Population of Study

Population is the entire group of attention which the scholar desires to examine or study [25]. It refers to clearly defined elements, service, people, things or households under investigation [25]. The target population in this study comprised of the daily confirmed COVID-19 cases in Kenya for the period ranging from 13th March 2020 to 30th November 2020, thus making the Units of analysis in this study to be 263 units.

3.2 Data Collection Instruments & Procedure

Secondary data collection methods were employed in collecting data which investigated the effect of COVID-19 and Inflation on the Foreign Exchange rate in Kenya [26]. Documents and reports from the central bank of Kenya (CBK), World Health Organization (WHO), the ministry of health of Kenya and the Kenya National Bureau of Statistics (KNBS) websites' were reviewed so as to gather the USD/KES exchange rate data, the daily confirmed cases of COVID-19 infections in Kenya and the Inflation rate (CPI) from 13th March 2020 to 30th November 2020.

The Regression Analysis Model was developed in the following manner.

$$Y = \beta_0 + \beta_1 X_1 + \beta_2 X_2 + \epsilon$$

Y is the predetermined value of the dependent variable (USD/KES Exchange rate).

β_0 is the Y intercept (Predictable value of Y, when X is zero).

β_1, β_2 are the regression coefficient (how much we expect Y to change as X increases).

X_1, X_2 are the independent variable (Daily confirmed cases of COVID-19 and the Daily Inflation rate (CPI)).

ϵ is the error term of the estimator (how much variation is in our estimate of the regression coefficient).

The coefficients generated from the Regression Analysis Model were used to test the null hypotheses at five percent (5%) significance level as shown in Table 2 which presents, summary of the hypothesis, regression test statistics, and decision rule. This research made use of tables to analyze and present the general trend of the data from 13th March 2020 to 30th November 2020.

Table 2. Summary of hypothesis, model, test statistics and decision rule

Hypothesis and Model	Test Statistics	Decision Rule
<p>H₀₁: COVID-19 has no significant effect on the Foreign Exchange rate in Kenya</p> <p>$Y = \beta_0 + \beta_1 X_1 + \epsilon$</p>	P value statistic and the linear regression analysis (Relationship between COVID-19 and the USD/KES Exchange rate in Kenya)	If ($H_{01}: p < \alpha$) Reject the Null hypothesis, otherwise accept it
<p>H₀₂: Inflation rate (CPI) has no significant effect on the Foreign Exchange rate in Kenya</p> <p>$Y = \beta_0 + \beta_2 X_2 + \epsilon$</p>	P value statistic and the linear regression analysis (Relationship between Inflation rate (CPI) and the USD/KES Exchange rate in Kenya)	If ($H_{02}: p < \alpha$) Reject the Null hypothesis, otherwise accept it

4. RESULTS AND DISCUSSION

This section presents the research findings, analysis and discussion of the variables via methods described in the previous section. Data analysis was coherent with the specific objectives where patterns were observed, construed and conclusion inferred on them. Finally decision was made based on the regression statistics results on whether to accept or reject the null hypothesis at 0.05 level of significance.

4.1 Correlation Analysis Results

Table 3. Correlation Coefficients of COVID-19 and Interest rate (CPI) against the USD/KES exchange rate for 263 observations

	USD/KES Exchange rate	Daily Confirmed cases of COVID-19	Interest rate (CPI)
USD/KES Exchange rate	1		
Daily Confirmed cases of COVID-19	0.6346	1	
Inflation rate (CPI)	0.7768	0.7273	1

4.1.1 Relationship between COVID-19 and the USD/KES exchange rate

The correlation results indicated a significant positive relationship between COVID-19 and the USD/KES exchange rate, indicating that a unit increase in COVID-19 results to an increase in the USD/KES exchange rate by 0.63 units.

4.1.2 Relationship between Inflation rate (CPI) and the USD/KES exchange rate

A significant positive relationship between inflation rate (CPI) and the USD/KES exchange rate was observed, indicating that a unit increase in inflation rate results to an increase in the USD/KES exchange rate by 0.77 units.

4.2 Reliability Test

Table 4. Regression statistics

Regression Statistics	
Multiple R	0.7834
R Square	0.6137
Adjusted R Square	0.6108
Standard Error	0.8570
Observations	263

The adjusted R Square from the regression statistics table of 0.613674022 indicates that over 61% of the variability of the USD/KES exchange rate has been accounted for by COVID-19 and the inflation rate (CPI). This indicated that the Regression Analysis Model used in modeling the study which investigated the effect of COVID-19 and Inflation rate on the Foreign Exchange rate in Kenya was reliable and significant.

4.3 Test of Significance

Table 5. ANOVA table

ANOVA					
	df	SS	MS	F	Significance F
Regression	2	303.3217	151.6609	206.5034	2.01376E-54
Residual	260	190.9500	0.73449		
Total	262	494.2718			

The significance F from the ANOVA table was used to test the overall fitness of the model. Now the results of significance F of -2.0^{54} is less than 0.05; ($-2.0^{54} < 0.05$) thus indicating that the regression model employed in this research was fit and statistically significant.

4.4 Regression Analysis Model

Table 6. Regression analysis table

	Coefficients	Standard Error	t Stat	P-value
Intercept	-8.817501	9.688675	-0.910083	0.363621
Daily Confirmed case of COVID-19	0.000578	0.000220	2.630698	0.009030
Interest rate (CPI)	1.067232	0.089557	11.916757	2.055E-26

The coefficients of regression from the regression Table 6 show a positive relation between COVID-19 and Inflation rate of 0.000578115 and 1.067232247 respectively against the USD/KES exchange rate. The p-value statistic (the Probability Value) from the regression table was used to test the null hypothesis, and decision made on whether to accept or reject the null hypothesis at 0.05; (If $p\text{-value} < \alpha$, reject the

null hypothesis and accept the alternate hypothesis).

4.5 Hypothesis Testing

The regression coefficient results from the regression model were employed in testing the null hypothesis at 0.05; (If $p\text{-value} < \alpha$, reject the null hypothesis and accept the alternate hypothesis), as shown in Table 7.

Table 7. Hypothesis testing

Hypothesis	P-value	Decision Rule
H ₀₁ : COVID-19 has no significant effect on the Foreign Exchange rate in Kenya	0.00902954	Reject H ₁ Since 0.00902954<0.05
H ₀₂ : Inflation Rate (CPI) has no significant effect on the Foreign Exchange rate in Kenya	2.05534E ⁻²⁶	Reject H ₂ Since 2.05534E ⁻²⁶ <0.05

4.6 Discussion of Results and Findings

The general objective of the study was to investigate the effect of COVID-19 and Inflation on the Foreign Exchange rate in Kenya. The study used Secondary data which was acquired from the World Health Organization (WHO), the ministry of health of Kenya, the Central Bank of Kenya (CBK) and the Kenya National Bureau of Statistics (KNBS) for a period ranging from 13th March 2020 to 30th November 2020. The data collected was analyzed using regression analysis, results interpreted and decision made on whether to accept or reject the null hypothesis at 5% level of significance.

The correlation results in Table 3 indicated a positive significant relationship between COVID-19 and the USD/KES exchange rate of 0.634560548. These results were consistent with the findings of Sansa [11] who studied the impact of COVID-19 on the financial markets: Evidence from China and USA, and found a positive significant relationship between COVID - 19 confirmed cases and the Shanghai stock exchange and New York Dow Jones stock exchange in China and USA.

The Daily confirmed cases of COVID-19 coefficient of regression was 0.00902954, which was less than 0.05, now the decision rule was to reject H₀₁ which stated that the Daily confirmed cases of COVID-19 have no significant effect on the foreign exchange rate in Kenya, since 0.00902954<0.05 (Decision rule: Reject the null hypothesis at 0.05; (if p-value< α)). The rejection of H₀₁ indicated that COVID-19 has a significant effect on the foreign exchange rate in Kenya. The results confirmed that COVID-19 contributed significantly to the deflection of the USD/KES exchange rate, which deflected from 102.4235 on 13/03/2020 to settle at 110.0535 on 30/11/2020. The results were consistent with the current economic affairs of the country due to the effect wrought by the COVID-19 pandemic. For instance, the tourism industry, for example which is an integral player in earning the country foreign income was hit hard, for instance in 2018, the tourism industry earned the country a total of

KES 157.4 billion and in 2019 the revenue rose by 3.9% to settle at KES 163.6 billion [8] however this scenario has changed significantly in this current year, 2020, due to the measures undertaken to curb the spread of COVID-19 pandemic such as closing of borders and the hotel industry, which directly affected the tourism industry and consequently the foreign income of the country which sent ripple effects to the USD/KES exchange rate in Kenya and the Kenyan economy at large.

The correlation results in Table 3 indicated a strong positive relationship between Inflation rate and the USD/KES Exchange rate in Kenya of 0.776782441. These results were consistent with the findings of Muchiri [15] who studied the effect of inflation and interest rates on the foreign exchange rates in Kenya and found a positive significant relationship between inflation (CPI) and the foreign exchange rate.

The Inflation rate coefficient of regression was 2.05534E⁻²⁶, which was less than 0.05, now the decision rule was to reject H₀₂ which state that Inflation rate (CPI) has no significant effect on the foreign exchange rate in Kenya, since 0.00902954<0.05 (Decision rule: Reject the null hypothesis at 0.05; (if p-value< α)). The results indicates that as the rate of inflation (CPI) changes, the USD/KES exchange is affected significantly. This is evident, since during the study period the (CPI) deflected from 107.3442 on 13/03/2020 to 110.7800 on 30/11/2020, this change in CPI consequently led to a change in the foreign exchange rate from 102.4235 to 110.0535 during the same period of study.

5. CONCLUSION AND RECOMMENDATIONS

5.1 Conclusion

In the empirical review, research works done by Barua [3], Surabhi [1], Sansa [11], Mert and Omer [19], Lelissa (2020) and Muchiri (2020) were reviewed.

The reviewed literature evidently established a gap since majority of the studies used a single

variable, other studies on the exchange rate for instance the research by Muchiri [15] was done prior to the COVID-19 pandemic and other studies on the COVID-19 pandemic were done outside Kenya. This present research consequently constricts the gap by establishing the effect of COVID-19 and Inflation on the Foreign Exchange rate in Kenya.

The research hypothesis tested in section 4 led to the rejection of H_{01} and H_{02} at 5% level of significance. This meant that COVID-19 and Inflation rate (CPI) significantly affect the Foreign Exchange rate in Kenya, hence requiring a close monitoring, and mitigation measures, so as to alleviate any adverse effect on the economy, this is because the study revealed that they have and an effect on foreign exchange rate which is a variable with a can consequently affect the economy.

5.2 Recommendations

After data analysis, hypothesis testing and interpretation, we recommend that: The government of Kenya and other policy formulators and partisan organizations such as the Central Bank of Kenya (CBK) and the Kenya National Bureau of Statistics (KNBS) ought to monitor closely the USD/KES exchange rate as the Kenya Shilling (KES) is deteriorating at an alarming rate against the United States Dollar (USD) since the confirmation of the first case of COVID-19 infection in the country on 13th March 2020. Proper policies should be formulated and mechanism put in place in ensuring that the Kenya shilling regains its position prior to the invasion of the COVID-19 in the country. We also recommend that the government of Kenya should think on increasing the foreign currency reserve so as to mitigate and hedge the Kenya Shilling against shocks and adverse fluctuations against foreign currencies.

6. SUGGESTIONS FOR FURTHER RESEARCH

For further Research it is proposed that another study may be carried out to cover current emerging issues which may affect the foreign exchange rate in Kenya and the economy at large, such as the current Building of Bridges Initiative (BBI) and the heated political temperatures in the country as the country approaches the electioneering period. Finally, the study recommends the use of different tools of analysis and the units of analysis under study to

be extended so as to increase reliability and generalization of results.

COMPETING INTERESTS

Authors have declared that no competing interests exist.

REFERENCES

1. Surabhi V, Anders G. Investigating the emerging COVID-19 research trends in the field of business and management: A bibliometric analysis approach. *Journal of Business Research*. 2020;118(2020):253-261.
2. World Health Organization. *Coronavirus Disease (COVID-19) Dashboard*; 2020.
3. Barua S. Understanding coronanomics: The economic implication of the coronavirus (COVID-19) (April 1, 2020). Available:SSRN:<https://ssrn.com/abstract=3566477>, <http://dx.doi.org/10.2139/ssrn.3566477>
4. James KJ, Martin AW, Adres BS. Global economic effects of COVID-19 congressional research service. Available:<https://crsreports.congress.gov/R46270>.
5. Pak A, Adegboye OA, Adekunle AI, Rahman KM, McBryde ES, Eisen DP. Economic Consequences of the COVID-19 Outbreak: the Need for Epidemic Preparedness. *Frontiers in Public Health*. 2020;8:241. Available:<https://doi.org/10.3389/fpubh.2020.00241>
6. Yeyati EL, Filippini F. Social and economic impact of COVID-19. *Brookings Global Working Paper #158 Global Economy and Development program at Brookings*; 2021. Available:www.brookings.edu/global
7. Noy, Ilan, Nguyen Doan, Benno Ferrarini, Donghyun Park. "The economic risk of COVID-19 in developing countries: Where is it highest?," *Vox eBook Chapters*, in Simeon Djankov & Ugo Panizza (Ed.), *COVID-19 in Developing Economies*, Edition 1. 2020;1(chapter 1):38-52, Centre for Economic Policy Research.
8. Kenya National Bureau of Statistics. *Inflation rate data*; 2020.
9. World Bank. *Unemployment, total (% of total labour force) (Modelled ILO estimate) Kenya*; 2020.

10. Central Bank of Kenya. Foreign exchange rate data; 2020.
11. Sansa N, Ali H. The Impact of COVID-19 on the Financial Markets: Evidence from China and USA. *Journal of Social Sciences and Humanities*. 2020;2(4):29-39.
12. Kivunja C. Distinguishing between Theory, Theoretical Framework, and Conceptual framework: A systematic review of lessons from the field. *International Journal of Higher Education*. 2018;7(6): 44-53. DOI: <https://doi.org/10.5430/ijhe.v7n6p44>
13. Thirlwall AP. *Inflation, Saving and Growth in Developing Economies*, Macmillan Publishers; 1974. ISBN: 9780333173107.
14. Cagan P. *Determinants and Effects of Changes in the Stock of Money, 1875–1960*. New York: Columbia University Press; 1965.
15. Muchiri M. Effect of inflation and interest rates on foreign exchange rates in Kenya [Unpublished MBA Thesis]. University of Nairobi; 2017.
16. Adom D, Emad KH. Theoretical and conceptual framework: Mandatory ingredients of a quality research. *International Journal of Scientific Research*. 2018;7(1):438-441.
17. Mandela A. The Effects of Exchange Rate Fluctuations on Export Earnings of Coffee Industry in Kenya. Masters Thesis, University of Nairobi; 2015.
18. Kenga SD. Effect of macroeconomic variables volatility on the financial performance of commercial banks listed at the Nairobi Securities Exchange, *Global Scientific Journals*. 2019;7(10). ISSN: 2320-9186.
19. Mert T, Omer SG. The Impact of COVID-19 on emerging stock markets. *Finance research Letters Journal*. 2020;36(2020): 10169. DOI:<https://doi.org/10.1016/j.frl.2020.101691>
20. Kamau CG, Ilamoya SL. *Accounting Profession: Steps into the Future (African Perspective)*. SSRN E-Journal (Working Paper Series). DOI:<https://dx.doi.org/10.2139/ssrn.3946885>
21. Indrajit B. Examining the Effect of COVID-19 on Foreign Exchange Rate and Stock Market. Department of Economic Studies and Policies, Central University of South Bihar; 2020.
22. Syed A, Fatima K, Zaheer M. The impact of COVID-19 on stock market and exchange rate uncertainty in Pakistan. *Business Review*. 2021;16(2):96-108. Available:<https://doi.org/10.54784/1990-6587.1423>
23. Banerjee R, Mehrotra A, Zampolli F. *Inflation at risk from Covid-19*. Bank for International Settlements; 2020. ISSN: 2708-0420.
24. Shapiro A. Monitoring the Inflationary effects of COVID-19. *FRBSF Economic Letter 2020-24 (August 24)*; 2020.
25. Umair M. Research Fundamentals: Study design, Population, and Sample size. *Journal of Undergraduate Research in Natural Clinical Science and Technology*. 2018;2(1):1-7.
26. Narayan PK. Has COVID-19 Changed Exchange Rate Resistance to Shocks? *Asian Economics Letters*. 2020;1(1). Available:<https://doi.org/10.46557/001c.17389>

© 2022 Shukrani et al.; This is an Open Access article distributed under the terms of the Creative Commons Attribution License (<http://creativecommons.org/licenses/by/4.0>), which permits unrestricted use, distribution, and reproduction in any medium, provided the original work is properly cited.

Peer-review history:

The peer review history for this paper can be accessed here:
<https://www.sdiarticle5.com/review-history/86953>