



Islamic Banking and Performance of Beneficial MSME's in Sumbawa; Study of BMT Insan Samawa

Reza Muhammad Rizqi ^{a*} and Joni Firmansyah ^b

^a Department of Accounting, Sumbawa University of Technology, Indonesia.

^b Department of Government Science, Sumbawa University of Technology, Indonesia.

Authors' contributions

This work was carried out in collaboration between both authors. Both authors read and approved the final manuscript.

Article Information

DOI: 10.9734/SAJSSE/2022/v14i330384

Open Peer Review History:

This journal follows the Advanced Open Peer Review policy. Identity of the Reviewers, Editor(s) and additional Reviewers, peer review comments, different versions of the manuscript, comments of the editors, etc are available here: <https://www.sdiarticle5.com/review-history/88600>

Short Research Article

Received 13 June 2022
Accepted 20 June 2022
Published 22 June 2022

ABSTRACT

Aims: The purpose of this research is to examine the role of Baitul Maal Wat Tamwil (BMT) Insan Samawa financing in the trade expansion and prosperity rises of its members from Sumbawa's small and medium-sized microbusinesses.

Study Design: Quantitative Research

Place and Duration of Study: BMT Insan Samawa Financing, between Mei 2022 and June 2022.

Methodology: The data was analyzed quantitatively using the smartPLS model with a survey approach. The purposive sampling technique yielded 40 respondents.

Results: The findings of this study show that financing has a significant positive effect on trade expansion, with the t statistic for the construct of financing and trade expansion being larger from 1,96 around 13,339 and the coefficient of latent variable financing on output path coefficient being around 0,729, indicating a positive effect of around 72,9% on trade expansion caused by the large of financing effect on trade expansion directly. Trade expansion has a significant positive effect on prosperity rises. The t statistic for the construct of financing on prosperity rises is greater than 1,96 around 6,120, and the coefficient of latent variable that is trade expansion on output path coefficient is around 0,633, which means that as the business grows, so will the welfare.

Conclusion: Financing has a significant effect on the growth of BMT Insan Samawa SMEs, as shown by the fact that the statistical t value for the PB constructs on PU is greater than 1.96, which is 13,339. This proves that PB has a significant effect on PU. Development business has a

significant effect on improving the welfare of the BMT Insan Samawa UMKM with Output path coefficient shows that the statistical t value for the PU construct on PK is greater than 1.96, which is 6.120, so the effect given by PU on PK is proven to be significant.

Keywords: Economic; financing; trade expansion; prosperity research.

1. INTRODUCTION

The issue of capital, in which acquiring money from banks can be problematic at times, is one of the most fundamental issues that are often debated by many parties in relation to MSMEs [1]. Such conditions necessitate that small and medium-sized businesses obtain appropriate cash from financial institutions. With the progression of time, management in the financial industry has become nonconventional and based on sharia. BMT is one model of a simple Islamic financial institution that operates among the lower economic community and tries to develop productive businesses and investments in order to improve the economy for small entrepreneurs based on sharia principles which are then channeled through financing (Prastiawati, 2016). BMT Insan Samawa is one of the BMTs that provides this type of financing Murabaha which is by 50%, musharaka financing by 28.75%, Qordhul Hasan financing by 14.01%, and Ijarah financing by 7.24%. This financing pattern is an attraction for MSME actors to partner with BMT Insan Samawa. Because there are certain advantages of each financing. As easy in terms of administration and processes in terms of implementation [2].

So far the partners of BMT Insan Samawa consist of several entrepreneurs from different business fields such as trading, craftsmen, street vendors, fisheries, and agriculture. BMT Insan Samawa has a number of active partners as many as 145 people who continue to grow and continue to strive to meet the desires and needs of partners with various programs and product choices to help partners to continue to improve their business. Because one of the goals of BMT Insan Samawa is to facilitate the progress of the ummah's economic cycle through the marketing mechanism of products from the ummah for the ummah. To determine the extent to which BMT finance affects the growth of MSME businesses, it is required to do research. The purpose of this study is to determine whether or not it is true that BMT funding has an impact on the growth and well-being of MSMEs [3].

MSMEs are economic sub-sectors that absorb a lot of labor and are in great demand by urban communities. MSMEs also play a very vital role in the national economy, because MSMEs can still survive in the midst of developments and the economic crisis that hit Indonesia [4].

The role of MSMEs in development is one of them to contribute to GDP, create jobs which result in a reduction in the unemployment rate and improve the quality of human resources. The problems that are often faced by MSMEs in Indonesia are lack of attention from the government, limited working capital and investment capital, difficulty in getting raw materials with good quality and affordable prices, limited technology, human resources with poor quality (management and production techniques), market information, and difficulties in marketing [4].

According to Mardani [5] the alternative programs to overcome MSME problems are by carrying out empowerment activities with priority scales as follows: 1) business climate creation program, 2) business support system development program, 3) development and competitiveness program, 4) micro-enterprise empowerment program, 5) program improving the quality of cooperative institutions so that they are able to grow and develop in a healthy and efficiency-oriented manner.

BMT is a financial institution whose main business is to provide financing and services that do not use interest but use a profit-sharing system whose products are based on the Qur'an and the Hadith of the Prophet SAW [5]. Role BMT in the community's economy, namely keeping people away from non-sharia economic practices, and providing funding accompanied by assistance and direction to MSME actors.

Financing or financing is the funding provided by one party to another to support the planned investment, whether carried out individually or by an institution. In other words, financing is funding issued to support planned investments [1]. The financing disbursed by BMT is different from the financing disbursed by conventional banks.

Conventional financing only provides loans to those in need and the profits they get from interest and fees by paying interest on the borrowed money. while sharia-based financing consists of several principles such as 1) the principle of profit-sharing or syirkah (profit sharing) where the financing facilities provided are in the form of cash or goods valued in money, 2) buying and selling or ba'i this principle is implemented because of the transfer ownership of goods or objects, 3) lease (ijarah) is a contract to utilize services, either service for goods or services for labor [6].

Schumpeter in his theory of economic growth explains that development is an increase in output caused by innovations made by tourists [7]. The benchmark for business development or business success must be a parameter that can be measured so that it is not relative or even difficult virtual for could be accounted for. The more concrete the benchmarks, the easier it is for all parties to understand and justify the achievement of these successes. Definition welfare improvement in on could be concluded that well-being is a condition where the Public fulfilled standard need good needs If these needs are met properly, the community will feel comfortable and able to carry out their activities and social function.

The benchmark to see the level of community welfare is very broad and complex. Thus, a level of welfare can only be assessed through measurable indicators from various aspects of development. Indicators that are usually used as benchmarks for increasing community welfare include the fulfillment of basic needs, additional needs, educational needs, health needs, and the need to save [8]. The research hypothesis is, that Allegedly financing BMT Insan Samawa affects business development, It is suspected that business development has an effect on increasing welfare, Suspected financing of BMT human Samawa is influential towards improving welfare through business development.

2. MATERIALS AND METHODS

This study aimed to determine the role of BMT financing for Insan Samawa which will then affect business development so that it is expected to have an impact on increasing the welfare of MSME actors in Sumbawa Regency.

The population used in this study were all MSME actors who received financing from BMT Insan Samawa in Sumbawa Regency. The sampling method used in this research is the purposive sampling method. The purposive sampling method is the determination of the sample based on certain considerations [9].

This study uses quantitative methods with a survey approach [9]. This type of research is in the form of field research conducted at the residence or place of business of the research respondent. The data collection methods in this study were carried out by: [10].

1. Designing a Structural Model (Inner Model);
2. Designing Model Measurement (Outer Model);
3. Model Evaluation;
4. Test Hypothesis (Resampling Bootstrapping);

3. RESULTS AND DISCUSSION

The Table 1 shows that about 5 people or 12.5% of respondents are male, and the remaining 35 people or 87.5% are female. In this case, one of the factors that cause women to be more dominant in terms of trading compared to men is because women know more about how to manage finances than men. And most men in Sumbawa themselves are more dominant by profession as farmers/planters.

Based on the Table 2, it can be seen that the number of respondents most of them were in Brang Bara, which amounted to 11 respondents or 27.5%, while the lowest respondent's business locations

Table 1. Description of respondents by gender

Gender	Amount	Percentage
Man	5	12.5%
Woman	35	87.5%
Total	40	100%

Source: Processed Primary Data, 2022

Table 2. Description of respondents based on business location

No	Business Location	Amount	Percentage
1	Brang bara	11	27.5%
2	Brang biji	7	17.5%
3	Kerato	9	22.5%
4	Kebayan	2	5%
5	Labuhan Sumbawa	2	5%
6	Nijang	3	7.5%
7	Jorok	1	2.5%
8	Kampung Irian	1	2.5%
9	Baiti Jannati	1	2.5%
10	Seketeng	2	5%
11	Kampung Bugis	1	2.5%
Total		40	100%

Source: Processed Primary Data, 2022



Fig. 1. Structural model of the variables construct (PB, PU, PK)

Source: Processed Primary Data, 2022

were Jorok, Irian Village, Baiti Jannati, and Bugis Village, each with 1 respondent, the amount of respondent chosen by author based on the number of people who used BMT Insan Samawa and the researcher distributes and collected the questionnaire via a google form. This is because the location of the BMT itself is very close to the location of the seed bran market, and for the location of Brang Biji and Kerato, there are more industrial centers in that location and the business is also quite large.

Based on the picture above, it shows that the design of the inner model or structural model in this study uses three latent constructs consisting of one exogenous latent construct, namely financing, and two endogenous latent constructs consisting of development. Effort and welfare improvement. For the Outer Model we can see it in this picture.

Based on the picture above, shows that the arrow is drawn from the latent construct to the indicator or manifest construct. This explains that each measurement of the indicator value in this study is reflected by its respective constructs, both financing constructs, development effort, and welfare improvement.

Convergent and Discriminant Validity Test: Based on the Table 3, it shows that the indicators of the amount of financing and the frequency of financing have a correlation to the financing construct, which is 0.954, and 0.965, this value is higher than the correlation to the construct of business development and welfare improvement. Likewise with the correlation of each construct other with indicators taller compared with the correlation of indicators with other constructs. This shows that the latent construct predicts its respective indicators better than the prediction of indicator correlation with other constructs.

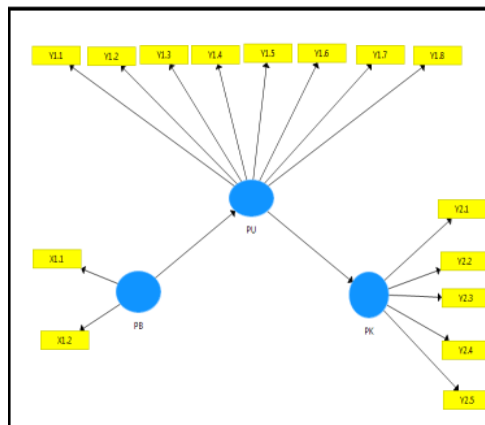

Fig. 2. Outer model of variables construct with indictor (PB, PU, PK)
 Source: Processed Primary Data, 2022

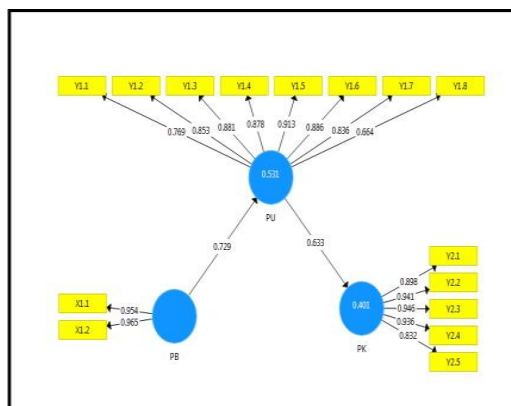

Fig. 3. Convergent Validity Test from Variabel Construct (when the value from a variable is <0,05 then it is not valid)
 Source: Processed Primary Data, 2022

Table 3. Discriminant validity test

Indicator	Construct			
	Financing	Business development	Enhancement prosperityaan	Information
Amount of financing	0.954	0.650	0.561	Valid
Frequency of financing	0.965	0.744	0.692	Valid
Income	0.628	0.769	0.485	Valid
Total manpower	0.544	0.853	0.398	Valid
Skills	0.604	0.881	0.480	Valid
Production quantity	0.545	0.878	0.526	Valid
Number of customers	0.577	0.913	0.539	Valid
Inventory	0.677	0.886	0.569	Valid
Profit	0.565	0.836	0.700	Valid
Business expansion	0.700	0.664	0.484	Valid
Basic needs	0.596	0.601	0.898	Valid
Additional needs	0.625	0.651	0.941	Valid
Educational needs	0.650	0.620	0.946	Valid
Health needs	0.588	0.534	0.936	Valid
Saving needs	0.523	0.445	0.832	Valid

Source: Processed Primary Data, 2022

Table 4. Output composite reliability and cronbach alpha

Construct	Cronbach Alpha	Composite Reliability	Information (> 0.70)
PB	0.915	0.959	Reliable
PU	0.938	0.950	Reliable
PK	0.949	0.961	Reliable

Source: Processed Primary Data, 2022

Convergent and Discriminant Validity Test: Based on the Table 4, shows that each construct of financing, business development, and welfare improvement has a Composite Reliability value greater than 0.70 so, all constructs are declared to have good reliability.

Hypothesis Test: The output results of Path Coefficients above do not show a positive relationship between constructs. This relationship can be seen in the original sample in the output path coefficients. The original sample values between constructs are as follows:

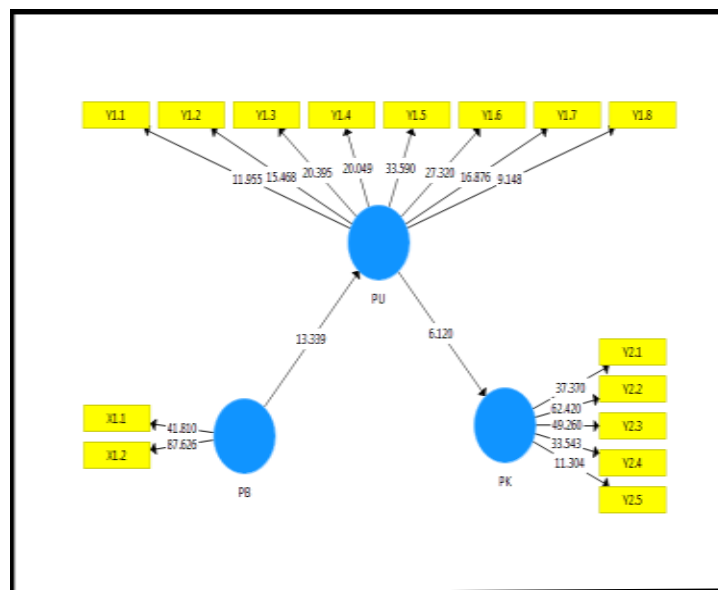

Fig. 4. Hypothesis Test from Variables Exogen to Endogen (PU, PB, PK Value should > 1,664)

Source: Processed Primary Data, 2022

Table 5. Sample original output

Construct	Original Sample (O)	T Statistics (O/STDEV)	Information (T Statistics > 1.96)
Financing -> business development	0.729	13.339	Significant
Business development -> welfare improvement	0.633	6,120	Significant

Source: Processed Primary Data, 2022

The following is an interpretation of the results of hypothesis testing that can be generated in the Path Coefficient in PLS Bootstrapping:

- 1 Hypothesis tests H1 (effect of business development on enhancement of well-being). based on the results data analysis shows that the financing construct has a significant effect on business development with a t-statistical value of 13.339 which is greater than the t-table of 1.96 and the value of the original sample estimate is positive, namely 0.729, then the direction of the financing relationship on business development is positive. Based on testing first hypothesis is that the proposed H1 is accepted. The output path coefficient shows that the statistical t value for the PB construct on PU is greater than 1.96, which is 13,339 so the effect given by PB on PU is proven to be significant. The influence given by PB to PU is proven positive with the coefficient value of the latent variable PB at the Output path coefficient of 0.729 which means there is a positive effect of 72.9% on the PU construct. This shows that the greater the financing, the greater the level of development of MSMEs. Based on a study Yunia [4] states that financing from BMT can provide an increase to traders in order to increase their business progress. If you listen to this, the program run by BMT Al Amin Makassar, namely through a mudharabah financing agreement, by providing capital to traders in need is very influential for the progress and improvement of their business. However, the role of the BMT is not only to provide capital loans but also to be accompanied by assistance and guidance by providing directions to members. In addition, the mudharabah financing contract carried out at BMT Al Amin Makassar has been running in accordance with the objectives of the BMT In general, it can improve the quality of people's economic efforts for the welfare of members and society. Especially in the mudharabah financing program, because

the existence of mudharabah financing is one way to help and ease the burden on the service sector, traders, and agriculture in terms of capital, which aims to increase their business to be better and develop than before. So that the existence of this mudharabah financing can make one way for the community to increase micro, small and medium enterprises.

- 2 Hypothesis test H2 (effect of business development on enhancement well-being). based on the results data analysis shows that the business development construct has a significant effect on upgrade welfare with a t-statistical value of 6.120 which is greater than the t-table of 1.96 and the original sample estimate value is positive, namely 0.633, then the direction of the relationship between business development and enhancement well-being is positive. Based on the second hypothesis testing, it is known that the proposed H2 is accepted. The output path coefficient shows that the statistical t value for the PB construct on PK is greater than 1.96, which is 6.120 so the effect given by PU on PK is proven to be significant. The influence given by PU to PK is proven to be positive with the coefficient value of the PU latent variable at the Output path coefficient of 0.633 which means there is a positive influence of 63.3% on the PK construct so that it is growing effort so welfare will also increase.

4. CONCLUSION

Based on the results of research and discussion of the influence of BMT Insan Samawa financing on business development and improved welfare of its members in the MSME sector in Sumbawa Regency through the distribution of questionnaires shows that:

1. Financing takes effect significantly towards the development of BMT Insan Samawa SMEs by *Output path coefficient* shows that the statistical t value for the PB construct on PU is greater than 1.96,

which is 13,339 so that the effect given by PB on PU is proven to be significant. The influence given by PB to PU has been proven to be positive with the value of the latent variable coefficient of PB at the Output path coefficient of 0.729, which means that there is a positive influence of 72.9% on the PU construct, so the greater the financing, the greater the development of MSMEs.

2. Development business has a significant effect on increasing the welfare of the BMT Insan Samawa UMKM with output path coefficient shows that the statistical t value for the PU construct on PK is greater than 1.96, which is 6.120 so that the effect given by PU on PK is proven to be significant. The effect of PU on PK has proven positive with the value of the coefficient of the latent variable of PU at the Output path coefficient of 0.633, which means that there is a positive effect of 63.3% on the PK construct, so that the more the business develops, the welfare will also increase.

CONSENT

As per international standard or university standard, respondents' written consent has been collected and preserved by the author(s).

COMPETING INTERESTS

Authors have declared that no competing interests exist.

REFERENCES

1. Latif, Abdul. Etika Persaingan dalam Usaha Menurut Pandangan Islam. *Jurnal of Islamic Economic*. 2017;3(2):298-312
2. Alias, Latif Rakib. Strategy Development Micro, Small and Medium Enterprises in Strengthening the Economy democracy. (Thesis, Makassar Public University); 2017. Available: <https://www.adb.org/projects/54367-002/main>
3. Abdulahanaa. Kaidah-kaidah Keabsahan Multi Akad (Hybrid Contract). Yogyakarta: Trust Media; 2019.
4. Yunia, Ika dan Abdul Kadir Riyadi. Prinsip Dasar Ekonomi Islam Perspektif Maqashid al-Syari'ah. 1st; Jakarta: Prenadamedia Group; 2018.
5. Mardani. Aspek Hukum Lembaga Keuangan Syariah di Indonesia. Jakarta: Kencana; 2019.
6. Karim, AA. Ekonomi Mikro Islami. Jakarta PT: Raja Grafindo Persada; 2017.
7. Ananda, Fitri. Analysis of the Development of Micro Enterprises Dan Small After Obtaining Mudharabah Financing From BMT AT-Taqwa Halmahera in Semarang City. (Thesis, Diponegoro University, Semarang); 2018. Available: <http://eprints.undip.ac.id/27920/>
8. Zuhdi, Afifudin. Eksistensi Ojek Pangkalan Di Tengah Adanya Ojek Online Perspektif Sosiologi Ekonomi Islam. *Fakultas Ekonomi dan Bisnis Islam lain. Jurnal of Islamic Economic*. 2018;7(3):45-52.
9. Sugiyono. Educational Research Methods (Quantitative, Qualitative, and R&D Approaches. Bandung: Alfabeta; 2018.
10. Harini S. Small Micro And Medium Enterprise Empowerment Strategy Through Stakeholder Involvement To Increase The Performance. *The Management Journal of Binaniaga*. 2019;04(02):34-44.

© 2022 Rizqi and Firmansyah; This is an Open Access article distributed under the terms of the Creative Commons Attribution License (<http://creativecommons.org/licenses/by/4.0>), which permits unrestricted use, distribution, and reproduction in any medium, provided the original work is properly cited.

Peer-review history:

The peer review history for this paper can be accessed here:

<https://www.sdiarticle5.com/review-history/88600>